



TRITON 20

HF-SSB Marine Radio

2.9/12.3-13.2 MHz 100 W PEP



Instruction Manual

68P81044E20-A



MOTOROLA INC.

**Communications
Group**

TRITON 20 HF-SSB MARINE RADIO

2-9/12.3-13.2 MHz
100 W PEP

CONTENTS

<i>Section</i>	<i>Number</i>
Specifications	Pages ii, iii
Foreward	Pages iv, v
Model Charts	Pages vi, vii
General Safety Information	EPS-28750
DESCRIPTION	68P81044E33
INSTALLATION	68P81044E28
OPERATING INSTRUCTIONS	68P81044E31
MAINTENANCE	68P81044E29
Receiver Troubleshooting Chart	DEPS-29258
Transmitter Troubleshooting Chart	DEPS-29257
MECHANICAL DISASSEMBLY	68P81044E48
ALIGNMENT	68P81044E32
THEORY OF OPERATION	68P81044E27
REFERENCE DIAGRAMS	
"A" Board	
Circuit Board Detail	PEPS-31351 (Sheet 1 of 3)
Schematic Diagram	(Sheets 2 and 3 of 3)
"B" Board	
Circuit Board Detail	PEPS-29297
Schematic Diagram	EEPS-29109
"C" Board	
Circuit Board Detail	PEPS-29303
Schematic Diagram	DEPS-29133
Harmonic Filter Board	
Circuit Board Detail	PEPS-29299
Schematic Diagram	DEPS-29097
Power Amplifier Board	
Circuit Board Detail	PEPS-29305
Schematic Diagram	EEPS-29101
Intercabling Diagram	EEPS-29138
MICROPHONE	68P81110E43

Motorola, and Triton 20 are trademarks of Motorola, Inc. © Motorola, Inc., 1980

© Motorola, Inc. 1980
All Rights Reserved
Printed in U.S.A.

technical writing services

1301 E. Algonquin Road, Schaumburg, IL 60196

68P81044E20-A
12/15/80-PHI

PERFORMANCE SPECIFICATIONS

GENERAL

Model Number:	D70SBA1G20BK
Frequency Range:	2.9, 12.3-13.2 MHz
Number of Channels:	20 Simplex maximum or up to 10 half duplex maximum
Power Output:	100 watts PEP
I-F Frequency:	11.4 MHz
Primary Voltage:	13.4 volts nominal $\pm 20\%$
Current Drain:	Receive — Standby: .9 Amps @ 13.8 V dc
(Over Stabilized	Full Audio: 2.5 Amps @ 13.8 V dc
-25°C Ambient):	1.5 amps @ 13.8 V dc
	Transmit — 100 watts PEP: Single tone 18 Amps
	2-tone PEP 13 Amps
Controls:	On-Off/Volume, channel select and A/B switch, squelch, clarifier, Dimmer Switch
Size:	35.6 cm (14") L 26.4 cm (10-3/8") W 8.6 cm (3-3/8") H
Weight:	7.72 kg (17 lbs.)
Mobile Mounting:	Front

TRANSMITTER

Power Output:	100 watts PEP
Intermodulation:	-32 dB reference to PEP
Spurious & Harmonic Emissions:	-63 dB reference to PEP
Carrier Suppression:	-46 dB
Transmission Modes:	A3A, A3J, A3H
Undesired Sideband Suppression:	1 kHz tone, -55 dB reference to PEP
Audio Distortion:	5% total distortion
Frequency Stability:	± 20 Hz, -20°C to +50°C (FCC) ± 40 Hz, -30°C to +60°C (DOC)
Transmitter Tuning Adjustments:	Frequency warp only

RECEIVER

Sensitivity:	10 dB SINAD: 0.5 μ V 1/2 rated audio power: 1.0 μ V/2.5 watts
Selectivity:	(-6 dB minimum) 350 Hz to 2700 Hz
Spurious and Image Rejection:	(Ref. 10 dB SINAD) at least 65 dB; Image at least 80 dB
Intermodulation:	-70 dB
Cross Modulation:	-90 dB
(100 kHz Separation)	
Desensitization:	-90 dB
(100 kHz Separation)	
Frequency Stability:	± 20 Hz, -20°C to +50°C (FCC) ± 40 Hz, -30°C to +60°C (DOC)
Audio Output:	5 watts with less than 10% total distortion
AGC Characteristics:	Audio output varies less than 2 dB for signals between 10 μ V and 1 volt (100 dB range) Dual slope, fast attack, slow decay AGC threshold 10 μ V or less
Squelch:	Constant SINAD
Receiver Tuning Adjustments:	Frequency warp only
Clarifier Range:	± 175 Hz, minimum

FCC & DOC INFORMATION

Model	Transmitter Peak Envelope Power (PEP)	Range	Rules	Emission Authorized	Type Acceptance Number
D70SBA	100 Watts	2.9 MHz/ 12.3-13.2 MHz	FCC 81,83,87,90 DOC RSS125,RSS181	A3A,A3J,A3H	CC1173

Note: Part 87 applies to airborne stations only. Not type accepted under paragraph 87.65 for ground stations.

OPTION CHART

Option	Description	Add	Delete
S501AA thru S520AA	Crystals	None	KXN6123AG Crystals (Qty. 1 thru 20 respectively)
ACCESSORIES			
Antenna Systems	A crucial element for reliable communications is the antenna system. Contact your local Motorola representative for individualized selection of the most appropriate system from a wide variety of tuners and antennas.		
AC Power Supply	The recommended TPN1177A Power Supply is a fully regulated and short circuit protected unit, which operates from either 50 or 60 Hz with line voltages of 100, 110, 120, 200, 210, 220, 230 or 240 V ac. Instruction section 68P81111E32 fully describes this power supply.		
Overhead Mounting Panel	The TRN4048A Overhead Mounting Panel allows convenient operation of the radio when mounted in the inverted position.		
Mounting Tray	Permanent mounting of the radio is provided by the TRN4047A Mounting Tray.		
Base Microphone	The convenience of a base microphone is available with the Model TMN1023A, described in instruction section 68P81103E48.		

FOREWORD

1. SCOPE OF MANUAL

This manual is intended for use by experienced technicians familiar with similar types of equipment. It contains all service information required for the equipment described and is current as of the printing date. Changes which occur after the printing date are incorporated by Instruction Manual Revisions (SMR). These SMR's are added to the manuals as the engineering changes are incorporated into the equipment.

2. MODEL AND KIT IDENTIFICATION

Motorola equipments are specifically identified by an overall model number on the nameplate. In most cases, assemblies and kits which make up the equipment also have kit model numbers stamped on them. When a production or engineering change is incorporated, the applicable schematic diagrams are updated.

As diagrams are updated, information about the change is incorporated into a revision column. This revision column appears in the manual next to the parts list or, in some cases, on the diagram. It lists the reference number, part number, and description of the parts removed or replaced.

3. SERVICE

Motorola's National Service Organization offers one of the finest nation-wide installation and maintenance programs available to communication equipment users. This organization includes approximately 900 authorized Motorola Service Stations (MSS) located throughout the United States, each manned by one or more trained, FCC licensed technicians.

These MSS's are independently owned and operated and were selected by Motorola to service its customers. Motorola maintenance is available on either a time and material basis or on a periodic fixed-fee type arrangement.

The administrative staff of this organization consists of national, area and district service managers and district representatives, all of whom are Motorola employees with the objective to improve the service to our customers.

Should you wish to purchase a service contract for your Motorola equipment, contact your Motorola Service Representative, or write to:

National Service Manager
Motorola Communications and Electronics, Inc.
1303 E. Algonquin Road
Schaumburg, Illinois 60196

4. REPLACEMENT PARTS ORDERING

Motorola maintains a number of parts offices strategically-located throughout the United States. These facilities are staffed to process parts orders, identify part numbers, and otherwise assist in the maintenance and repair of Motorola Communications Group products.

Orders for all parts *except* crystals, active filters, code plugs, channel elements, and "Vibrasender"® and "Vibrasponder"® resonant reeds should be sent to the nearest area parts center. Orders for instruction manuals should also be sent to the area parts center.

When ordering replacement parts or equipment information, the complete identification number should be included. This applies to all components, kits, and chassis. If the component part number is not known, the order should include the number of the chassis or kit of which it is a part, and sufficient description of the desired component to identify it.

Orders for crystals, channel elements, active filters, code plugs, and reeds should be sent directly to the factory address listed on the following page. Crystal and channel element orders should specify the crystal or channel element type number, crystal and carrier frequency, and the chassis model number in which the part is used.

Orders for active filters, code plugs, "Vibrasender" and "Vibrasponder" resonant reeds should specify type number and frequency, and should identify the owner/operator of the communications system in which these items are to be used.

5. ADDRESSES

5.1 GENERAL OFFICES

MOTOROLA Communications and Electronics
Inc.
Communications Group Parts Dept.
1313 E. Algonquin Rd.,
Schaumburg, Illinois 60196
Phone: 312-576-3900

5.2 U.S. ORDERS

WESTERN AREA PARTS
1170 Chess Drive, Foster City,
San Mateo, California 94404
Phone: 415-349-3111
TWX: 910-375-3877

MIDWEST AREA PARTS
1313 E. Algonquin Road
Schaumburg, Ill. 60196
Phone: 312-576-7322
TWX: 910-693-0869

MID-ATLANTIC AREA PARTS
7230 Parkway Drive
Hanover, Maryland 20176
Phone: 301-796-8600
TWX: 710-862-1941

EAST CENTRAL AREA PARTS
12995 Snow Road,
Parma, Ohio 44130
Phone: 216-267-2210
TWX: 810-421-8845

EASTERN AREA PARTS
85 Harristown Road,
Glen Rock, New Jersey 07452
Phone: 201-447-4000
TWX: 710-988-5602

PACIFIC SOUTHWESTERN AREA PARTS
P.O. Box 85036
San Diego, California 92138
Phone: 714-578-2222
TWX: 910-335-1634

GULF STATES AREA PARTS
8550 Katy Freeway
Suite 128
Houston, Texas 77024
Phone: 713-932-8955

SOUTHWESTERN AREA PARTS
P.O. Box 34290
3320 Belt Line Road,
Dallas, Texas 75234
Phone: 214-241-2151
TWX: 910-860-5505

SOUTHEASTERN AREA PARTS
P.O. Box 368
Decatur, Georgia 30031
Phone: 504-981-9800
TWX: 810-766-0876

5.3 CANADIAN ORDERS

**CANADIAN MOTOROLA ELECTRONICS
COMPANY**
National Parts Department
3125 Steeles Avenue,
East Willowdale, Ontario
Phone: 416-499-1441
TWX: 610-492-2713
Telex: 02-29944LD

5.4 ALL COUNTRIES EXCEPT U.S. AND CANADA

**MOTOROLA, INC. OR MOTOROLA
AMERICAS, INC.**
International Parts Dept.
1313 E. Algonquin Road
Schaumburg, Illinois 60196 U.S.A.
Phone: 312-576-6492
TWX: 910-693-0869
Telex: 722443 or 722424
Cable: MOTOL PARTS

5.5 FACTORY ADDRESS FOR CRYSTAL, CHANNEL ELEMENT, ACTIVE FILTER, CODE PLUGS AND RESO- NANT REED ORDERS

ALL MAIL ORDERS
Motorola, Inc.
Component Products Sales & Service
P.O. Box 66191
O'Hare International Airport
Chicago, Ill. 60666

CORRESPONDENCE
Motorola, Inc.
Component Products Sales & Service
2553 N. Edgington Street
Franklin Park, Illinois 60131

GENERAL SAFETY INFORMATION



The United States Department of Labor, through the provisions of the Occupational Safety and Health Act of 1970 (OSHA), has established an electromagnetic energy safety standard which applies to the use of this equipment. Proper use of this radio will result in exposure below the OSHA limit. The following precautions are recommended:

DO NOT operate the transmitter of a mobile radio when someone outside the vehicle is within two feet (0.6 meter) of the antenna.

DO NOT operate the transmitter of a fixed radio (base station, microwave and rural telephone rf equipment) or marine radio when someone is within two feet (0.6 meter) of the antenna.

DO NOT operate the transmitter of any radio unless all RF connectors are secure and any open connectors are properly terminated.

In addition,

DO NOT operate this equipment near electrical blasting caps or in an explosive atmosphere.

All equipment must be properly grounded according to Motorola installation instructions for safe operation.

All equipment should be serviced only by a qualified technician.

Refer to the appropriate section of the product service manual for additional pertinent safety information.

EPS-28750-O



1. INTRODUCTION

The Motorola *Triton 20* is a solid state two-way high frequency single sideband radio which features 100 watt PEP transmitter output on up to 20 simplex channels. Any frequency within the 2-9 MHz range can be placed on any of the 20 channels which are selected by two front panel switches. The 12.3 to 13.2 MHz band is made up of a 12.3 to 13.2 MHz receive range and a 12.3 to 12.45 MHz transmit range. Transmit and receive

frequencies can only be placed in these ranges for this band (12.3-13.2 MHz). Up to ten half-duplex channels (transmit and receive on different frequencies, but not simultaneously) can also be used, at the expense of losing two simplex channels for each half-duplex channel pair desired. An extensive line of accessories including several types of antennas and tuners, base microphone, ac power supply, mounting tray, and overhead mounting panel are available. See listing of radio options and accessories.

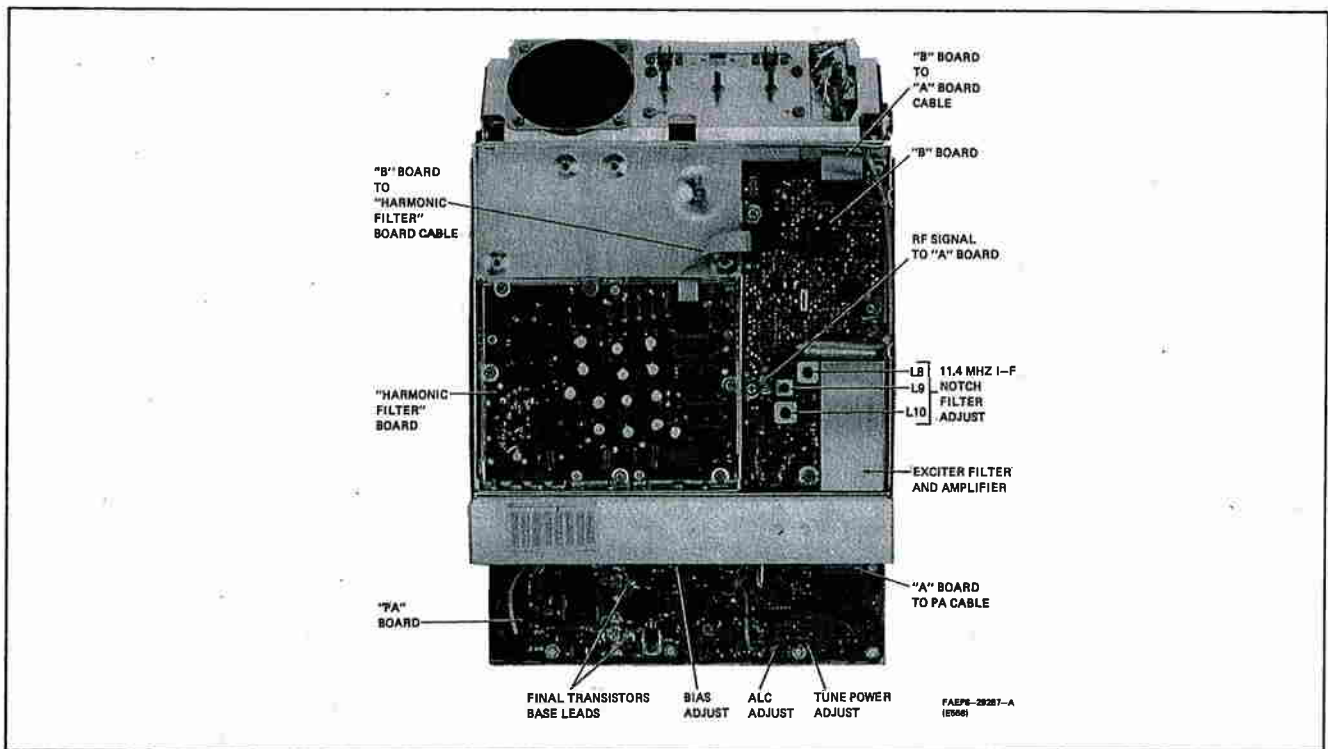

*Figure 1. Major Assemblies
as Seen From Top of Radio (PA Hinged Open)*

technical writing services

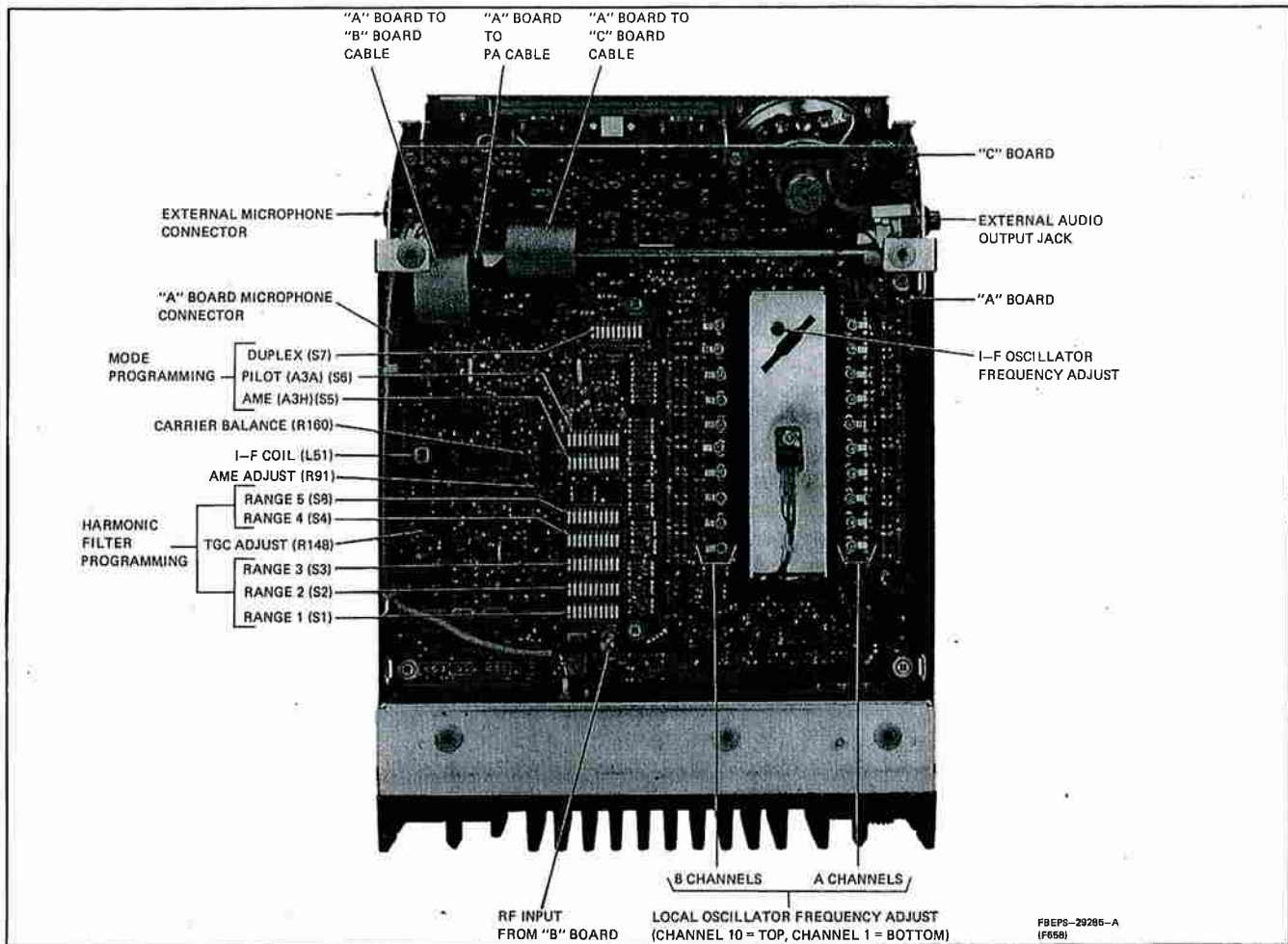

Figure 2. Major Assemblies as Seen From Bottom of Radio

2. PHYSICAL DESCRIPTION

The radio set transmitter, receiver, and control unit, are assembled in a fully enclosed housing. The local control unit includes an integral speaker and a sloping front panel that places the operating controls within easy reach. The radio may be mounted in any position with the accessory mounting tray.

The radio set construction is functionally separated onto five printed circuit boards. Interconnections

between these boards are made with multi-conductor ribbon cables and coaxial cables with connectors to facilitate easy board removal and repair. Refer to Figures 1 and 2 for locations of major assemblies.

The *Triton 20* is designed for 12 V dc negative ground operation and may be connected directly to a 12 V battery. The unit is supplied with four rubber feet on the bottom of the housing. For installation the radio can either be set on a flat surface or permanently mounted with the accessory tray.



MOTOROLA INC.

Communications
Group

INSTALLATION

MOUNTING INSTRUCTIONS

Step 1. Determine the desired method of mounting before installation. The radio can be mounted in any convenient position if the accessory mounting tray is used. If overhead mounting is desired, the accessory overhead mounting panel kit should be used. The selected location should allow enough clearance for connection of cables to the back of the radio.

Step 2. If the overhead mounting front control panel is used, remove the existing front panel as outlined in the Mechanical Disassembly section and replace it with the overhead panel. Also, replace the channel selector knob with the inverted selector knob supplied with the overhead panel kit.

Step 3. If the mounting tray is used, perform the following steps:

3a. Mount the tray to the appropriate location. The tray can be used as a template if drilling is required.

3b. Affix the mounting tray bracket to the bottom of the radio housing with the four supplied screws.

Step 4. If a 12 volt battery is used as a power source, perform the following steps:

4a. Pass the long red, green, and black power cables through any wall necessary to make connections to the battery.

4b. Connect the lugs on the short red and green cables to the positive (ungrounded) terminal of the battery.

4c. Affix the supplied lug to the end of the black wire and connect this to the negative (grounded) terminal of the battery.

4d. Insert the unassembled ends of the fuse holder cap onto the long ends of the red and green wires, and fasten the fuse clips to these wires.

4e. Install the appropriate size fuses in the cable kit. The 30 amp fuse is for the red lead and the 7-1/2 amp fuse is for the green lead.

Step 5. If a dc converter is used as a power source, perform the following steps.

5a. Pass the long red, green, and black power cables through any wall necessary to make connections to the converter.

5b. Connect the lugs on the short red and green cables to the positive output terminal of the converter. The red cable goes to the 25A terminal and the green cable to the 5A terminal.

5c. Connect the black wire to the negative output terminal of the converter.

5d. Insert the unassembled ends of the fuse holder cap onto the long ends of the red and green wires, and fasten the fuse clips to these wires.

5e. Install the appropriate size fuses in the cable kit. The 30 amp fuse is for the red lead and the 7-1/2 amp fuse is for the green lead.

Step 6. If the ac supply is used, attach the supplied *Triton 20* power connector to the output cable of the supply. Connect the supply input to the appropriate ac source.

Step 7. Install the antenna and route the coaxial cable and tuner cable (if used) to the radio. Follow instructions supplied with the antenna and tuner.

INSTALLATION

technical writing services

Step 8. Connect the power cable, antenna coax, and tuner cable (if used) to the radio.

Step 9. Slide the radio into the mounting tray (if used) and fasten the tray bracket (already installed on the radio housing) to the tray with the two screws supplied.

Step 10. Install the microphone hang-up clip in a convenient location.

Step 11. Tape or tie up any extra cable.

Step 12. An external speaker or headphone set may be plugged into the jack on the side of the radio. A standard 1/4" phone plug is required to make the connection. Any speaker with impedance of 2 ohms or greater may be used. If it is desired to have the internal speaker muted when the external speaker is plugged in, the jumper on the speaker jack must be cut.



MOTOROLA INC.

Communications
Group

OPERATING INSTRUCTIONS

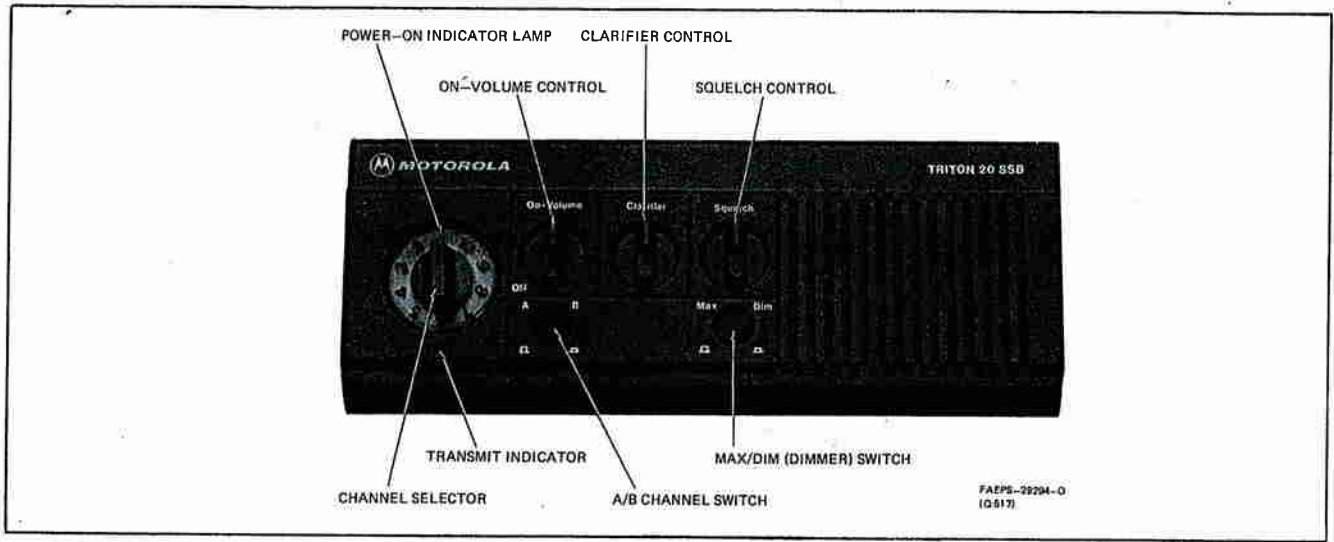

1. TO RECEIVE

Step 1. Turn on the external power source.

Step 2. Set the dimmer switch to the desired intensity of the power-on indicator lamp.

Step 3. Set the channel selector and A/B channel switch to the desired channel. If this is a half-duplex channel, the A/B channel switch must be in the A position to monitor the ship receive frequency and the B position to monitor the ship transmit frequency. The switch is normally in the A position which is the ship receive frequency.

Step 4. Turn the On-Volume control clockwise to turn the radio on and allow a 15 minute warmup to stabilize the crystal oven temperature.

Step 5. Turn the Squelch control fully counterclockwise.

Step 6. Advance the On-Volume control until noise is heard in the speaker.

Step 7. With no signal present, gradually advance the Squelch control clockwise until the noise is squelched (silenced). A very gradual adjustment is necessary due to the approximate 1.5 second delay in squelch response.

Step 8. Adjust the On-Volume control for a comfortable listening level during reception of a signal.

Step 9. If the voice quality of the received signal sounds either high-pitched or low-pitched, it is an indication that the incoming signal is off-frequency. Adjust the Clarifier control for the most natural voice quality. When the Clarifier control is near its mid-position, incoming signals that are on the correct frequency should sound normal.

2. TO TRANSMIT

Step 1. Set the channel select and A/B channel switch to the desired channel.

OPERATING INSTRUCTIONS

technical writing services

Step 2. Monitor the channel to make sure it is clear. **Do not transmit if the channel is in use.** If this is a duplex channel, place the **A/B** switch the **B** position to monitor the transmit frequency. Return the switch to the **A** position to hear the response on the duplex channel.

Step 3. After determining that the channel is clear, depress the PTT button on the microphone and speak

into microphone using a normal tone of voice. The transmit indicator should light when speaking into the microphone indicating that power is being delivered to the antenna.

Step 4. Identify the station being called and then identify your station.

Step 5. To hear the reply, release the PTT button on the microphone.



1. PREVENTIVE MAINTENANCE

1.1 VISUAL INSPECTION

Check all external surfaces of the equipment to see that they are clean. Inspect all connecting cables for damage or loose connections.

If the equipment is dirty, wash the external surfaces with mild soap and water using a clean cloth. Be careful not to allow the electronic components or connectors to get wet.

1.2 PERIODIC CHECKS

It is recommended that the transmitter channel frequencies and the i-f oscillator frequency be checked and adjusted after the first, third, seventh, and twelfth months and yearly, thereafter. If any crystals are replaced, the above schedule should be repeated for the first year.

At initial installation and yearly thereafter, perform the power output and half power output transmitter tests and the 10 dB SINAD and half power sensitivity receiver tests. Record these readings each time they are made and compare them with previous readings to detect any possible deterioration.

2. RECOMMENDED TEST EQUIPMENT

Item	Purpose
AC Voltmeter — S-1053	Used to measure all audio voltages.
DC Multimeter — S-1063	Used to measure all dc voltages.
RF Millivoltmeter — S-1339	Used to measure rf voltages for trouble isolation.
Oscilloscope — R-1004	Used for checking waveforms and troubleshooting.
Audio Oscillator — S-1067	Used for audio troubleshooting and adjustment.
Frequency Counter — S-1343	Used for frequency adjustment.
Wattmeter — S-1350	Used for measuring transmitter power output.

Item	Purpose
RF Load — T-1013	Dummy load used for transmitter.
In-Line Coupling Unit as per Figure 2 of Alignment section.	Used for coupling a sample of rf output to test equipment.
RF Signal Generator R-1020	For servicing receiver.
High Current Power Supply — R-1011	For supplying power to radio when out of vehicle.

3. CHANNEL ALIGNMENT AND PROGRAMMING

3.1 SELECTING CHANNEL FREQUENCIES

Transmitter channel operating frequencies can be added or changed only if proper licenses are obtained from the applicable governmental licensing agency. If properly authorized, operating frequencies can be easily added or changed as described below.

3.2 ORDERING CRYSTALS

Calculate the crystal frequency required using the following formula:

$$F_{\text{crystal}} = F_{\text{carrier}} + 11.4 \text{ MHz}$$

Order local oscillator crystals for each new frequency required by specifying crystal type KXN6123AG, the desired crystal frequency (as determined from the formula), the desired carrier frequency, and the model number in which the crystals are used. Order crystals as described in the forward of this manual.

For half-duplex channels, two crystals are required. Insert the receive crystal in the "A" side of the oven and the transmit crystal in the "B" side of the oven in the sockets corresponding to the channel number. (Refer to Figure 1). See the section entitled "PROGRAMMING CHANNELS" for duplex programming details.

MAINTENANCE

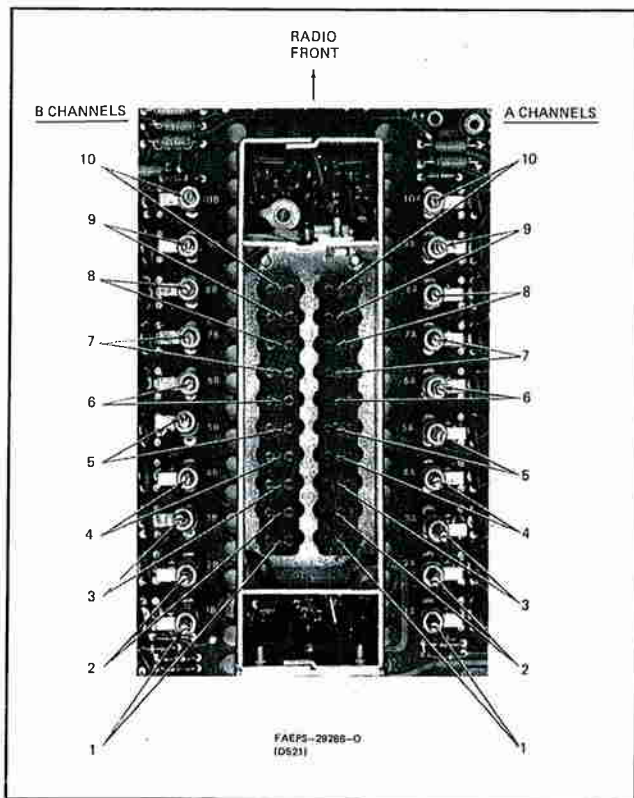

Figure 1. Local Oscillator Crystals and Trimmer Location

3.3 PROGRAMMING CHANNELS

The six sets of dual in-line switches on the "A" board must be programmed to ensure that the proper mode of operation, harmonic filter range, and type of channel (simplex or half-duplex) are selected for each channel. Refer to Figure 2.

3.3.1 Mode Programming

The mode programming switches are programmed to select one of three transmission modes for each channel. The three possible modes are designated as A3A (pilot carrier, -16 dB carrier), A3H (AME, -6 dB carrier), and A3J (SSB). Both the "A" and "B" side of each channel *will* be the same mode of transmission. For example, if AME transmission is programmed on channel 1A, AME will also be transmitted on channel 1B. If SSB is programmed on channel 2A, SSB will also be transmitted on channel 2B. Only one mode switch must be selected for each channel number.

The A3A (pilot carrier) mode of transmission is programmed on a channel by closing the pilot programming switch which has the same number as the channel that is selected. Also, the AME programming switch which has the same number as the selected channel must be opened for pilot carrier programming. Repeat this procedure for each channel which is to transmit in the pilot carrier mode.

The A3H (AME) mode of transmission is programmed on a channel by closing the AME programming switch which has the same number as the channel that is selected. Also, the pilot programming switch which has the same number as the selected channel must be opened for AME programming. Repeat this procedure for each channel which is to transmit in the AME mode.

The A3J (SSB) mode of transmission is programmed on a channel by opening both the pilot and AME programming switches which have the same number as the channel that is selected. Repeat this procedure for each channel which is to transmit in the SSB mode.

3.3.2 Range Programming

The range programming switches are programmed to select the proper filter range for each channel. Only one range switch must be selected for each channel number. The range required for a given channel frequency is determined by referring to Table 1. Both the "A" and "B" side of each channel *must* be in the same frequency range. To range program a channel, select the appropriate range from Table 1. Select the appropriate set of DIP switches from Figure 2 that corresponds to the desired range. Close the switch that has the same number as the channel that is selected. Open all other range switches having that number.

Table 1. Harmonic Filter Range Selection

Triton 20		
Filter Range	Minimum Frequency (kHz)	Maximum Frequency (kHz)
1	2000.00	2999.99
2	3000.00	4499.99
3	4500.00	6999.99
4	7000.00	10000.00
5	12300.00	13200.00

For duplex channels, the range is programmed for the transmit frequency. For proper receiver operation, the receive frequency must be in the same range as the transmit frequency.

The duplex programming switches are programmed to enable half-duplex operation on up to 10 selected channels.

In duplex operation, the receive crystal is located on the "A" side of the oven while the transmitter crystal is located on the "B" side of the oven. Duplex operation is programmed on a channel by closing the duplex programming switch which has the same number as the channel that is selected. In addition to this, the "A/B" front panel switch must be in the "A" position to receive on the duplex receive frequency and in the "B" position to receive on the transmit frequency. When the internal switch is programmed for duplex, the transmitter operates on the same frequency without regard to the "A/B" switch setting on that channel.

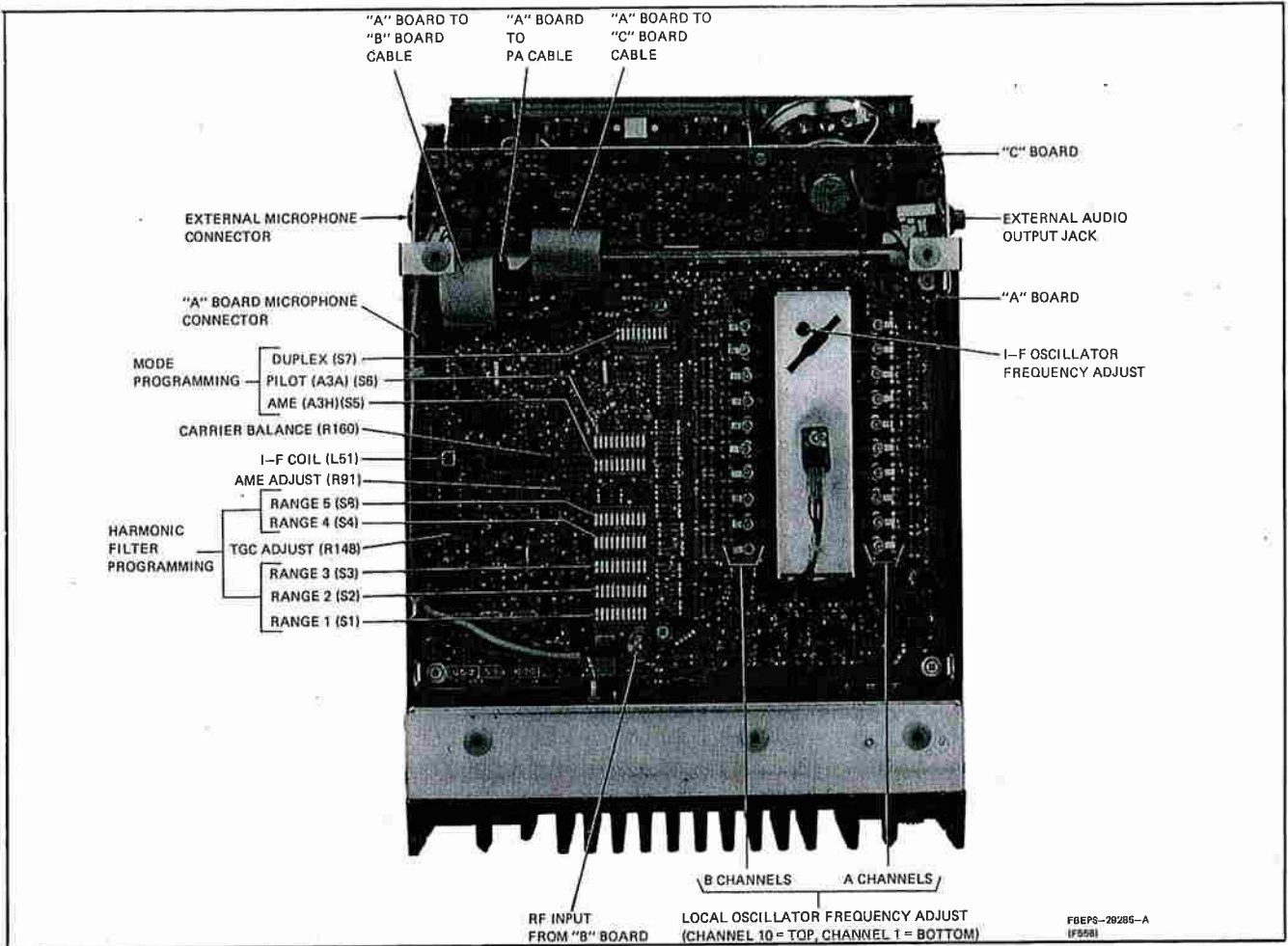

Figure 2. "A" Board Programming and Adjustment

PERFORMANCE SPECIFICATIONS

GENERAL

Model Number:	D70SBA1G20BK
Frequency Range:	2-9, 12.3-13.2 MHz
Number of Channels:	20 Simplex maximum or up to 10 half duplex maximum
Power Output:	100 watts PEP
I-F Frequency:	11.4 MHz
Primary Voltage:	13.4 volts nominal \pm 20%
Current Drain:	Receive — Standby: .9 Amps @ 13.8 V dc
(Oven Stabilized	Full Audio: 2.5 Amps @ 13.8 V dc
-25°C Ambient):	1.5 amps @ 13.8 V dc
	Transmit — 100 watts PEP: Single tone 18 Amps
	2-tone PEP 13 Amps
Controls:	On-Off/Volume, channel select and A/B switch, squelch, clarifier, Dimmer Switch
Size:	35.6 cm (14") L 26.4 cm (10-3/8") W 8.6 cm (3-3/8") H
Weight:	7.72 kg (17 lbs.)
Mobile Mounting:	Front

TRANSMITTER

Power Output:	100 watts PEP
Intermodulation:	-32 dB reference to PEP
Spurious & Harmonic Emissions:	-63 dB reference to PEP
Carrier Suppression:	-46 dB
Transmission Modes:	A3A, A3J, A3H
Undesired Sideband Suppression:	1 kHz tone, -55 dB reference to PEP
Audio Distortion:	5% total distortion
Frequency Stability:	\pm 20 Hz, -20°C to + 50°C (FCC) \pm 40 Hz, -30°C to + 60°C (DOC)
Transmitter Tuning Adjustments:	Frequency warp only

RECEIVER

Sensitivity:	10 dB SINAD: 0.5 μ V 1/2 rated audio power: 1.0 μ V/2.5 watts
Selectivity:	(-6 dB minimum) 350 Hz to 2700 Hz
Spurious and Image Rejection:	(Ref. 10 dB SINAD) at least 65 dB; Image at least 80 dB
Intermodulation:	-70 dB
Cross Modulation: (100 kHz Separation)	-90 dB
Desensitization: (100 kHz Separation)	-90 dB
Frequency Stability:	\pm 20 Hz, -20°C to + 50°C (FCC) \pm 40 Hz, -30°C to + 60°C (DOC)
Audio Output:	5 watts with less than 10% total distortion
AGC Characteristics:	Audio output varies less than 2 dB for signals between 10 μ V and 1 volt (100 dB range) Dual slope, fast attack, slow decay AGC threshold 10 μ V or less
Squelch:	Constant SINAD
Receiver Tuning Adjustments:	Frequency warp only
Clarifier Range:	\pm 175 Hz, minimum

FCC & DOC INFORMATION

Model	Transmitter Peak Envelope Power (PEP)	Range	Rules	Emission Authorized	Type Acceptance Number
D70SBA	100 Watts	2-9 MHz/ 12.3-13.2 MHz	FCC 81,83,87,90 DOC RSS125,RSS181	A3A,A3J,A3H	CC1173

Note: Part 87 applies to airborne stations only. Not type accepted under paragraph 87.65 for ground stations.

OPTION CHART

Option	Description	Add	Delete
S501AA thru S520AA	Crystals	None	KXN6123AG Crystals (Qty. 1 thru 20 respectively)
ACCESSORIES			
Antenna Systems	A crucial element for reliable communications is the antenna system. Contact your local Motorola representative for individualized selection of the most appropriate system from a wide variety of tuners and antennas.		
AC Power Supply	The recommended TPN1177A Power Supply is a fully regulated and short circuit protected unit, which operates from either 50 or 60 Hz with line voltages of 100, 110, 120, 200, 210, 220, 230 or 240 V ac. Instruction section 68P81111E32 fully describes this power supply.		
Overhead Mounting Panel	The TRN4048A Overhead Mounting Panel allows convenient operation of the radio when mounted in the inverted position.		
Mounting Tray	Permanent mounting of the radio is provided by the TRN4047A Mounting Tray.		
Base Microphone	The convenience of a base microphone is available with the Model TMN1023A, described in instruction section 68P81103E48.		

RECEIVER TROUBLESHOOTING

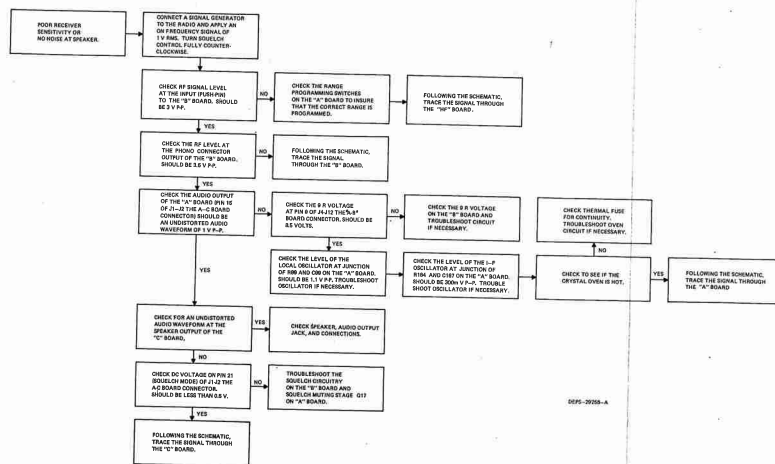

DEPS-29258-A

Motorola No. DEPS-29258-A
12/15/80-PHI

MAINTENANCE

TRANSMITTER TROUBLESHOOTING

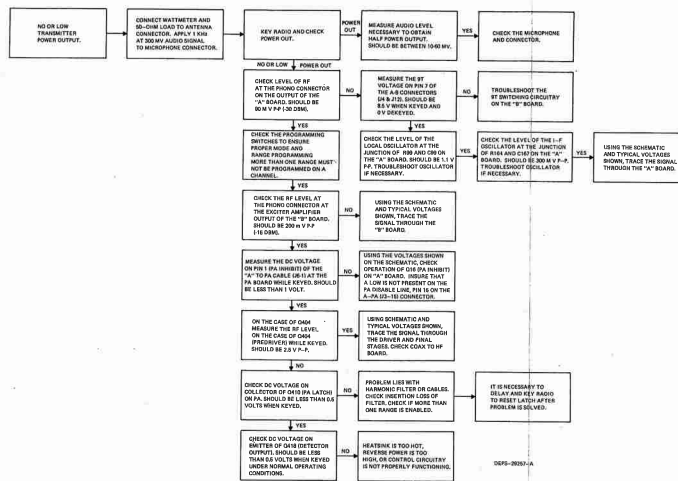

Motorola No. DEPS-29257-A
12/15/80-PHI

MECHANICAL PARTS AND DISASSEMBLY PROCEDURES

MECHANICAL DISASSEMBLY

Refer to the accompanying diagram for part number locations.

RADIO REMOVAL FROM MOUNTING TRAY

Step 1. Loosen the two screws (#61) which hold the tray bracket to the tray.

Step 2. While facing the radio, grasp the sides of the housing and pull the radio forward. The radio should now be released from the mounting tray.

RADIO HOUSING REMOVAL

Step 1. Disconnect power supply, coaxial, and tuner cables from radio.

Step 2. Remove the radio from the mounting tray (if used).

Step 3. Loosen and remove the five screws on the bottom of the housing. Three screws are located along the back of the housing and two screws are located along the front of the housing. It should not be necessary to remove the mounting tray bracket from the housing.

Step 4. Slide off the radio housing.

FRONT CONTROL PANEL REMOVAL

Step 1. Remove the radio housing.

Step 2. Loosen and remove the three screws (#53) located along the inside top front of the radio chassis.

Step 3. Remove all front panel control knobs (#2, 3, 5).

Step 4. Carefully tilt the front panel out from the top.

Step 5. Lift the front panel out of the slots located near the bottom of the front panel housing. Be careful not to break the tabs on the bottom of the front panel.

68P81044E48-A
(Sheet 1 of 2)
12/15/80-PHI

CONTROL PANEL HOUSING REMOVAL

Step 1. Remove the radio housing and front control panel.

Step 2. Loosen and remove the two screws (#8) located along the bottom of the control panel housing.

Step 3. Remove the control panel housing (#16).

LOCAL OSCILLATOR CRYSTAL ACCESS

Step 1. Remove the radio housing.

Step 2. Loosen the nut (#50) that holds down the foam oven cover.

Step 3. Remove foam oven cover.

Step 4. Carefully lift the oven cover using the handle strap on the cover. Be careful as the oven may be hot.

Step 5. The local oscillator crystals should now be visible.

POWER AMPLIFIER (PA) BOARD ACCESS

Step 1. Remove the radio housing.

Step 2. Loosen the two screws (#84) on the back of the PA heatsink.

Step 3. The PA heatsink is mounted on hinges and can be tilted down to access the PA board.

POWER AMPLIFIER (PA) BOARD REMOVAL FROM HEATSINK

The PA board can usually be serviced without removal. However, if removal is necessary, the following procedure may be used.

Step 1. Loosen and remove the four screws (#60) that secure the final amplifier devices. (NOTE: Do not lose thermistor clip.)

Step 2. Loosen and remove the three screws that secure the three other flat pack transistors, on the board.

Step 3. Loosen and remove the seven screws that hold the board to the heat sink.

Step 4. Remove the five coaxial cables with phone connectors from the receptacles on the inside of the PA compartment.

Step 5. Loosen and remove the screw (#28) that holds the black ground wire to the chassis.

Step 6. Unsolder the red A+ wire from the terminal strip inside the PA compartment.

Step 7. Loosen and lift the "B" board to allow removal of the "PA" to "A" board ribbon cable from the radio chassis.

Step 8. Remove the PA board.

"A" BOARD REMOVAL

NOTE
Disregard the number notation on the body of ribbon connectors P2, P3, P4 and P13. Always refer to your manual for connector position numbering.

Step 1. Remove metal radio housing and place radio on flat surface in front of you.

Step 2. Orient radio so that the PA heatsink is closest to you and "A" board directly in front of you.

Step 3. Remove ribbon cable connectors P2, P3, P4; MIC connector P5; coax connector P108 and RED SW A- connector located on the upper right hand corner of the "A" board.

Step 4. Remove the six (6) "A" board mounting screws.

Step 5. Lift the upper right-hand corner of the "A" board past the right chassis mounting tab while keeping the bottom right-hand corner of the board down near the bottom mounting tab.

Step 6. As the board clears the upper right-hand chassis mounting tab, slowly pull the board to the right of the radio keeping components clear from the A+ feedthru located on the back wall of the "A" board compartment.

Step 7. Remove the "A" board.

"B" BOARD REMOVAL

Step 1. Remove the housing from the radio.

Step 2. Disconnect the coax cable from the phono jack (#59) on the "B" board.

Step 3. Disconnect the ribbon cable (#99) from the "HF" board and the ribbon cable that connects the "B" board to the "A" board (#87).

Step 4. Disconnect the green wire on the "B" board from the push pin that runs to the harmonic filter board.

Step 5. Open the PA compartment as outlined in the Power Amplifier Board Access section.

Step 6. Disconnect the coax cable at the phono connector (#102) that runs between the "PA" and the "B" boards.

Step 7. Loosen and remove the five screws (#28) that secure the "B" board to the chassis.

Step 8. Remove the "B" board.

HARMONIC FILTER (HF) BOARD REMOVAL

Step 1. Remove the radio housing.

Step 2. Remove the harmonic filter cover, (#96).

Step 3. Disconnect the ribbon cable that connects the "HF" board to the "B" board.

Step 4. Disconnect the green wire on the "B" board push pin that connects the HF board and "B" board.

Step 5. Open the PA compartment as outlined in the Power Amplifier Board Access section.

Step 6. Loosen and remove the three screws (#28) in the PA compartment that secures the harmonic filter shield housing to the chassis.

Step 7. Disconnect the four coax cables that connect the "HF" board to the "PA" board from the phono receptacles in the PA compartment.

Step 8. Loosen and remove the seven screws (#107) that secure the HF shield (#91) to the chassis.

Step 9. The "HF" board and shield assembly may now be removed.

Step 10. If the shield must be removed from the "HF" board, loosen and remove the five screws (#28) that hold the "HF" board to the shield.

Step 11. Unsolder the four phono connectors from the bottom of the "HF" board.

Step 12. The board may now be removed from the shield.

CONTROL ("C") BOARD REMOVAL

Step 1. Remove the radio housing.

Step 2. Remove the front control panel and control panel housing as outlined in the front panel housing and control panel housing removal sections.

Step 3. Loosen and remove the four screws (#28) that secure the heatsink mounting bracket (#20) of the "C" board to the chassis (#45).

Step 4. Loosen and remove the nut that holds the speaker jack (#24) in the chassis and remove the jack from the chassis.

Step 5. Loosen and remove the screw (#28) in the corner of the "C" board near the speaker that holds the "C" board to the chassis.

Step 6. Dis

Step 7. Dis

Step 8. Lift

Step 9. Dis

Step 10. Re

Step 11. If

Step 12. Lo

Step 13. Re

Step 14. It s

CONTROL PANEL HOUSING REMOVAL

Step 1. Remove the radio housing and front control panel.

Step 2. Loosen and remove the two screws (#8) located along the bottom of the control panel housing.

Step 3. Remove the control panel housing (#16).

LOCAL OSCILLATOR CRYSTAL ACCESS

Step 1. Remove the radio housing.

Step 2. Loosen the nut (#50) that holds down the foam oven cover.

Step 3. Remove foam oven cover.

Step 4. Carefully lift the oven cover using the handle strap on the cover. Be careful as the oven may be hot.

Step 5. The local oscillator crystals should now be visible.

POWER AMPLIFIER (PA) BOARD ACCESS

Step 1. Remove the radio housing.

Step 2. Loosen the two screws (#84) on the back of the PA heatsink.

Step 3. The PA heatsink is mounted on hinges and can be tilted down to access the PA board.

POWER AMPLIFIER (PA) BOARD REMOVAL FROM HEATSINK

The PA board can usually be serviced without removal. However, if removal is necessary, the following procedure may be used.

Step 1. Loosen and remove the four screws (#60) that secure the final amplifier devices. (NOTE: Do not lose thermistor clip.)

Step 2. Loosen and remove the three screws that secure the three other flat pack transistors, on the board.

Step 3. Loosen and remove the seven screws that hold the board to the heat sink.

Step 4. Remove the five coaxial cables with phone connectors from the receptacles on the inside of the PA compartment.

Step 5. Loosen and remove the screw (#28) that holds the black ground wire to the chassis.

Step 6. Unsolder the red A+ wire from the terminal strip inside the PA compartment.

Step 7. Loosen and lift the "B" board to allow removal of the "PA" to "A" board ribbon cable from the radio chassis.

Step 8. Remove the PA board.

"A" BOARD REMOVAL

NOTE

Disregard the number notation on the body of ribbon connectors P2, P3, P4 and P13. Always refer to your manual for connector position numbering.

Step 1. Remove metal radio housing and place radio on flat surface in front of you.

Step 2. Orient radio so that the PA heatsink is closest to you and "A" board directly in front of you.

Step 3. Remove ribbon cable connectors P2, P3, P4; MIC connector P5; coax connector P108 and RED SW A+ connector located on the upper right hand corner of the "A" board.

Step 4. Remove the six (6) "A" board mounting screws.

Step 5. Lift the upper right-hand corner of the "A" board past the right chassis mounting tab while keeping the bottom right-hand corner of the board down near the bottom mounting tab.

Step 6. As the board clears the upper right-hand chassis mounting tab, slowly pull the board to the right of the radio keeping components clear from the A+ feedthru located on the back wall of the "A" board compartment.

Step 7. Remove the "A" board.

"B" BOARD REMOVAL

Step 1. Remove the housing from the radio.

Step 2. Disconnect the coax cable from the phono jack (#59) on the "B" board.

Step 3. Disconnect the ribbon cable (#99) from the "HF" board and the ribbon cable that connects the "B" board to the "A" board (#87).

Step 4. Disconnect the green wire on the "B" board from the push pin that runs to the harmonic filter board.

Step 5. Open the PA compartment as outlined in the Power Amplifier Board Access section.

Step 6. Disconnect the coax cable at the phono connector (#102) that runs between the "PA" and the "B" boards.

Step 7. Loosen and remove the five screws (#28) that secure the "B" board to the chassis.

Step 8. Remove the "B" board.

HARMONIC FILTER (HF) BOARD REMOVAL

Step 1. Remove the radio housing.

Step 2. Remove the harmonic filter cover, (#96).

Step 3. Disconnect the ribbon cable that connects the "HF" board to the "B" board.

Step 4. Disconnect the green wire on the "B" board push pin that connects the HF board and "B" board.

Step 5. Open the PA compartment as outlined in the Power Amplifier Board Access section.

Step 6. Loosen and remove the three screws (#28) in the PA compartment that secures the harmonic filter shield housing to the chassis.

Step 7. Disconnect the four coax cables that connect the "HF" board to the "PA" board from the phono receptacles in the PA compartment.

Step 8. Loosen and remove the seven screws (#107) that secure the HF shield (#91) to the chassis.

Step 9. The "HF" board and shield assembly may now be removed.

Step 10. If the shield must be removed from the "HF" board, loosen and remove the five screws (#28) that hold the "HF" board to the shield.

Step 11. Unsolder the four phono connectors from the bottom of the "HF" board.

Step 12. The board may now be removed from the shield.

CONTROL ("C") BOARD REMOVAL

Step 1. Remove the radio housing.

Step 2. Remove the front control panel and control panel housing as outlined in the front panel housing and control panel housing removal sections.

Step 3. Loosen and remove the four screws (#28) that secure the heatsink mounting bracket (#20) of the "C" board to the chassis (#45).

Step 4. Loosen and remove the nut that holds the speaker jack (#24) in the chassis and remove the jack from the chassis.

Step 5. Loosen and remove the screw (#28) in the corner of the "C" board near the speaker that holds the "C" board to the chassis.

Step 6. Disconnect the ribbon cable that connects the "C" board to the "A" board.

Step 7. Disconnect the red switched A+ wire push pin on the "A" board that runs between the "C" board and "A" board.

Step 8. Lift "C" board and heatsink assembly out of chassis and rotate.

Step 9. Disconnect push pins number 1, 2, 29, 30 from the "C" board.

Step 10. Removal of "C" board and heatsink assembly from the radio should now be possible.

Step 11. If removal of heatsink from board is required, loosen and remove four screws (#28) that hold the "C" board to the heatsink.

Step 12. Loosen and remove the two screws (#33) that hold the flat pack transistors to the side of the heatsink.

Step 13. Remove the nut and washer (#18, 19) that secure the channel selector switch to the heatsink.

Step 14. It should now be possible to lift the heatsink away from the "C" board.

MECHANICAL PARTS AND DISASSEMBLY PROCEDURES

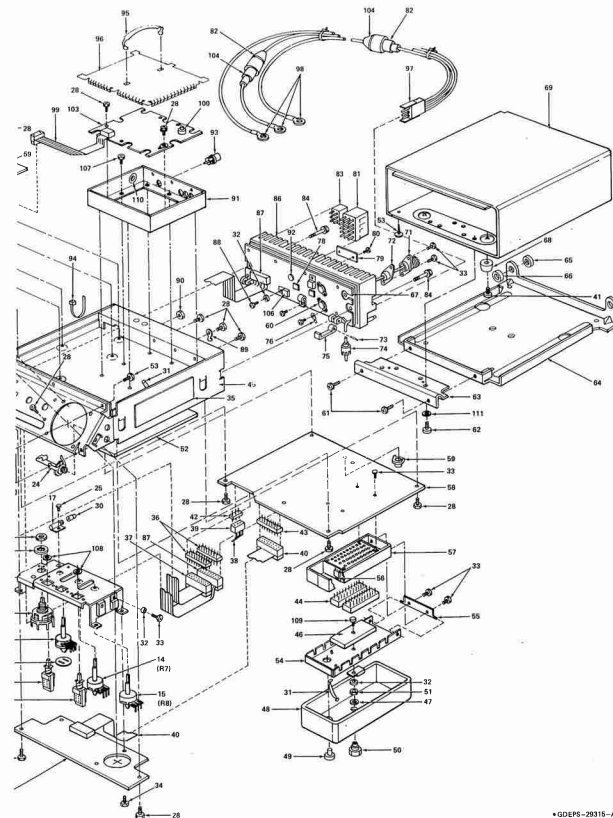

parts list

Radio Mechanical Parts (Marine) PL 6749-A

REFERENCE SYMBOL	MOTOROLA PART NO.	DESCRIPTION
1		TMN6151 Microphone Kit
2	38-8348M01	BUTTON, push; 2 used
3	38-84481L01	KNOB, control; 3 used
4	64-8326M01	PANEL, control
5	38-84906L03	KNOB, channel select
6	14-83419M01	INSULATOR
7	61-8326M01	LIGHT GUIDE, diffuser
8	3-13217	SCREW, tapping; 8-20 x 3/4"; 2 used
9	4-7665	WASHER, lock; 2 used
10	15-8206M01	HOUSING, microphone connector
11	9-84681L01	RECEPTACLE, microphone, 8-contact
12	3-13891	SCREW, tapping; 4-24 x 1/4"; 3 used
13	38-8258M01	GRILLE CLOTH
14	18-82519M02	RESISTOR, variable
15	18-82519M03	RESISTOR, variable
16	15-83261M01	HOUSING, control head
17	9-8349M01	SOCKET, lamp; 2 used
18	2-1378	NUT, hex; 3/8-32 x 1/2 x 3/32"
19	7-83257M01	BRACKET, heat sink mounting
20	40-83242M01	SWITCH, rotary; 10-position
21	18-82520M03	RESISTOR, variable
22	40-84282D06	SWITCH, push/button; 2 used
23	9-84257M01	JACK, speaker
24	3-13012	SCREW, machine; 4-40 x 1/4"; 2 used
25	2-8265	NUT, hex; 1/4-28 x 3/8 x 5/32"
26	14-8390M01	INSULATOR
27	3-13811	SCREW, tapping; 6-32 x 5/16; 40 used
28	84-8265M01	CIRCUIT BOARD ("C" Board)
29	65-84891D03	LAMP, incandescent; .08A, 14 V
30	55-84973E01	HANDLE; 2 used
31	4-64152B01	WASHER, shoulder; 6 used
32	3-13412	SCREW, tapping; 4-40 x 5/16"; 15 used
33	3-13861	SCREW, tapping; 6-32 x 5/16"
34	64-8326M01	LABEL, frequency
35	28-83579M01	CONNECTOR, plug; 20-contact; 2 used
36	30-8326M02	CABLE, flat; 20-conductor
37	29-8469D01	CABLE, flat; 20-conductor
38	15-83498F08	HOUSING, connector
39	30-8326M03	CABLE, flat; 20-conductor
40	3-13891	SCREW, tapping; 6-32 x 5/16; 4 used
41	28-83498F08	CONNECTOR, male; 3-contact
42	28-8379M02	CONNECTOR, plug; 25-contact
43	9-8326M01	SOCKET, crystal; 20-contact; 2 used
44	27-8326M01	CHASSIS, radio
45	14-83588K02	INSULATOR (pio 1-80717D20)
46	42-10219A32	RETAINER, push-on (pio 1-80717D20)
47	14-83755K02	INSULATOR, oven (pio 1-80717D20)
48	38-83755K02	CAP, plastic
49	2-83719M01	NUT, nylon
50	2-7019	NUT, hex; 4-40 x 1/4 x 3/32" (pio 1-80717D20)
51	14-84005K02	INSULATOR, board
52	3-13947	SCREW, tapping; 8-18 x 1/2; 8 used
53	15-8351K01	COVER, osc. oven (pio 1-80717D20)
54	7-8374K01	BRACKET, osc. oven (pio 1-80717D20)
55	17-8356K01	BRACKET, crystal holder
56	15-8325M01	HOUSING, osc. oven (pio 1-80717D20)
57	84-8256M01	CIRCUIT BOARD ("A" Board)
58	9-83018F01	JACK, phone
59	7-80078A01	BRACKET, thermostat mounting
60	14-8326M01	INSULATOR, heat sink
61 thru 66		TRIMMERS Mounting Tray
67	75-8372M01	BUMPER
68	15-8326M01	HOUSING
69	75-84380F01	BUMPER, 3 used
70	9-867432	RECEPTACLE, antenna
71	15-84110G01	PIVOT
72	47-83255M01	HOOD, receptacle antenna
73	47-83255M01	PIVOT
74	28-82365D02	PLUG, phone; 7 used
75	46-83254M01	LINK; 2 used
76	7-80078A01	BRACKET (thermostat mounting)
77	50-84710G02	SPEAKER, dynamic

REFERENCE SYMBOL	MOTOROLA PART NO.	DESCRIPTION
78	75-83238M02	PAD, transformer; 2 used
79	33-8448L01	NAMEPLATE
80	3-8162	SCREW, drive; 2 used
81	9-8326M01	CONNECTOR, female; 15-contact
82	14-8265A01	INSULATOR, fuse holder cap; 2 used
83	9-8306M01	CONNECTOR, female; 8-contact
84	3-8443D01	SCREW, retaining; 2 used
85	84-8304M01	CIRCUIT BOARD ("B" Board)
86	28-8326M02	HEATSINK
87	30-8326M01	CABLE, flat; 20-conductor
88	3-138613	SCREW, machine; 4-40 x 3/8"; 7 used
89	29-855907	LUG
90	2-11598	NUT, hex; 1/4-28 x 3/8 x 1/8"
91	26-8324M01	SHIELD, harmonic filter
92	14-061196	INSULATOR, transistor
93	944135B04	RECEPTACLE, phone; 4 used
94	42-10217A02	STRAP, tie; 15 used
95	55-84200D01	HANDLE
96	15-8326M01	COVER, harmonic filter
97	15-83488F26	HOUSING, connector; 3-contact
98	39-8306M01	CONTACT, retractor; 3 used
99	30-8326M04	CABLE, flat; 10-conductor
100	14-83967A03	WASHER, shoulder
101	26-8326M01	SHIELD, exciter
102	9-8325M01	RECEPTACLE, phone
103	84-8205M01	CIRCUIT BOARD (harmonic filter)
104	14-8265A01	INSULATOR, fuse holder body; 2 used
105	28-83579M03	CONNECTOR, plug; 10-contact; 1 used
106	14-84268A01	INSULATOR, transistor; 5 used
107	3-134185	SCREW, machine; 6-32 x 1/4"; 7 used
108	4-10255B32	WASHER, felt; 2 used
109	3-138906	SCREW, tapping; 4-40 x 1/2"
110	5-10115A23	GROMMET
111	4-114825	WASHER, 4 used
non-referenced items		
3-8162		SCREW, driver; 0-6 x 3/16"; 2 used
3-116102		SCREW, tapping; 8-32 x 3/8"; 4 used
3-7487		SCREW, tapping; 8-18 x 3/8"; 7 used
13-815918		DECAL, patent number
4-7607		WASHER, flat; 125-201-027"
14-8326M01		INSULATOR, connector; 15-position
14-8326M02		INSULATOR, connector; 3-position
14-8326M03		INSULATOR, connector; 6-position
26-82671D01		SHIELD, coil L8, 10
26-8704F01		SHIELD, coil L8, 10
30-8379A021		CABLE, coaxial; 44-112" used
30-813233		CABLE, battery; blk., 10' used
30-831572		CABLE, battery; blk., 10' used
30-83061G01		CABLE, coaxial; type RG17888U; 8-112" used
29-855943		PN terminal; 3 used
29-855947		LUG, ring tongue
29-831116		LUG, ring tongue; 2 used
29-83428B02		LUG, terminal; 2 used
29-83167C01		TERMINAL, strain relief; 12 used
29-82038E01		LUG, feed thru; 2 used
39-10184A10		CONTACT, plug; 5 used
42-6298A01		CLIP, fuse; 4 used
41-8268A21		SPRING, fuse compressor; 2 used
42-8473F01		RING, compression; 5 used
30-87388C01		GASKET; 2 used
76-8326M01		GORP, ferrite
33-8448L01		NAMEPLATE

*GDEPS-29315-A

68P81044E48-A
(Sheet 2 of 2)
12/15/80-PHI

MECHANICAL PARTS/DISASSEMBLY PROCEDURES

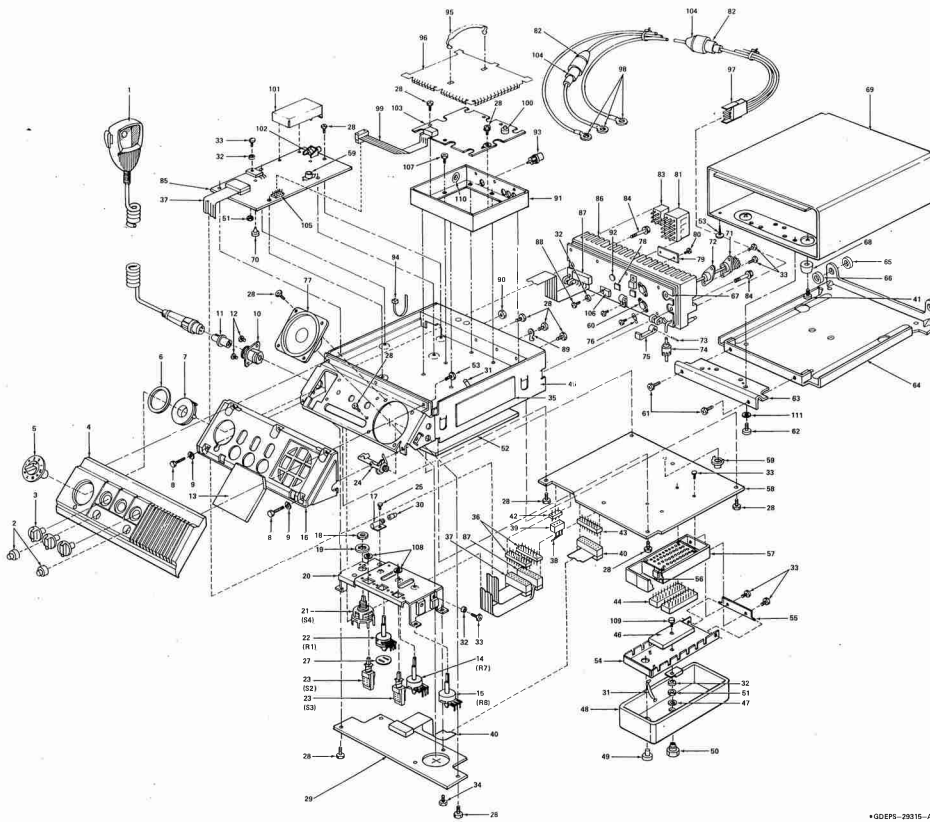

parts list

REFERENCE SYMBOL	MOTOROLA PART NO.	DESCRIPTION	REFERENCE SYMBOL
1	38-83448M01	TMN151 Microphone Kit	78
2	35-84891L01	BUTTON, push, 2 used	79
3	36-84208M01	KNOB, control, 3 used	80
4	36-8496L03	PANEL, control	81
5	36-8496L03	KNOB, channel select	82
6	14-83418M01	INSULATOR	83
7	51-8328M01	LIGHT GUIDE, diffuser	84
8	3-152127	SCREW, tapping: 6-20 x 3/4"; 2 used	85
9	4-7666	WASHER, lock, 2 used	86
10	15-82060M01	HOUSING, microphone connectr	87
11	9-84891L01	RECEPTACLE, microphone, 5-contact	88
12	3-138891	SCREW, tapping: 4-24 x 1/4"; 3 used	89
13	35-83298M01	GRILLE CLOTH	90
14	18-82519M02	RESISTOR, variable	91
15	18-82519M03	RESISTOR, variable	92
16	19-83291M01	HOUSING, control head	93
17	9-83549M01	SOCKET, lamp, 2 used	94
18	2-1216	NUT, hex: 3/8-32 x 1/2 x 3/32"	95
19	4-7655	WASHER, lock: #30 flt.	96
20	7-83257M01	BRACKET, heat sink mounting	97
21	40-83424M01	SWITCH, relay: 10 position	98
22	18-82520M03	RESISTOR, variable	99
23	40-84282D06	SWITCH, pushbutton; 2 used	100
24	9-64257M01	JACK, speaker	101
25	3-135102	SCREW, machine: 4-40 x 1/4"; 2 used	102
26	2-8265	NUT, hex: 1/4-28 x 3/8 x 3/32"	103
27	14-83000M01	INSULATOR	104
28	5-138611	SCREW, tapping: 6-32 x 5/16; 40 used	105
29	84-82965M01	CIRCUIT BOARD ("C" Board)	106
30	85-84691D03	LAMP, incandescent: .08A, 14 V	107
31	55-84973E01	HANDLE; 2 used	108
32	4-84152D01	WASHER, shoulder; 5 used	109
33	3-138112	SCREW, tapping: 4-40 x 5/16"; 15 used	110
34	3-138011	SCREW, tapping: 6-32 x 5/16"	111
35	64-83090M01	LABEL, frequency	
36	28-83579M01	CONNECTOR, plug; 20-contact; 2 used	
37	33-83265M02	CABLE, flat; 20-conductor	
38	29-84659D01	CONNECT, pins; 3 used	
39	15-83489F28	HOUSING, connector	
40	20-83265M03	CABLE, flat; 26-conductor	
41	3-138891	SCREW, tapping: 6-32 x 5/16; 4 used	
42	28-83496F28	CONNECTOR, male; 3-contact	
43	28-83579M02	CONNECTOR, plug; 26-contact; 2 used	
44	19-83880E01	SOCKET, crystal; 20-contact; 2 used	
45	27-83246M01	CHASSIS, radio	
46	14-83586K02	INSULATOR (pto 1-80717D20)	
47	45-10519A32	RETAINER, push-on (pto 1-80717D20)	
48	14-83755K02	INSULATOR, oven (pto 1-80717D20)	
49	38-83763K02	CAP, plastic	
50	2-83710M01	NUT, nylon	
51	2-7019	NUT, hex: 4-40 x 1/4 x 3/32" (pto 1-80717D20)	
52	14-84005K02	INSULATOR, board	
53	3-139047	SCREW, tapping: 8-18 x 1/2; 8 used	
54	15-83516K01	COVER, osc. oven (pto 1-80717D20)	
55	7-83754K01	BRACKET, osc. oven (pto 1-80717D20)	
56	17-83566C01	BRACKET, crystal holder	
57	15-83265M01	HOUSING, osc. oven (pto 1-80717D01)	
58	84-82055M01	CIRCUIT BOARD ("A" Board)	
59	8-82019F01	JACK, phone	
60	7-80078A01	BRACKET, thermistor mounting	
61 thru 66		TRIMMERS Mounting Tray	
67	14-83288M01	INSULATOR, heat sink	
68	75-83726M01	BUMPER	
69	15-83298M01	HOUSING	
70	75-84380F01	BUMPER; 3 used	
71	9807432	RECEPTACLE, antenna	
72	15-84110G01	HOOD, receptacle antenna	
73	47-83255M01	PIVOT	
74	28-82365D02	PLUG, phone; 7 used	
75	45-83254M01	LINK; 2 used	
76	7-80078A01	BRACKET (thermistor mounting)	
77	50-84710G02	SPEAKER, dynamic	

• GDEPS-29315-A



1. ROUTINE CRYSTAL FREQUENCY ADJUSTMENT

Crystal frequency setting should be performed as required and when replacing or adding new crystals.

CAUTION

Whenever replacing a channel crystal verify that the harmonic filter programming is correct, the antenna and tuner (if used) are properly adjusted, and the mode selection is programmed as desired.

1.1 I-F OSCILLATOR FREQUENCY ADJUSTMENT

Step 1. Turn the radio on and allow 15 minutes for the oven temperature to stabilize.

Step 2. Connect a frequency counter through a .01 uF coupling capacitor to the output of the i-f coax at R164 on the "A" board.

Step 3. Remove only the plastic access cap from the oven insulating cover, and using an insulated tuning tool adjust the piston trimmer capacitor for a reading of 11.400000 MHz \pm 2 Hz (see Figure 1).

Step 3. Remove the counter and restore the plastic access cap on the oven cover.

1.2 LOCAL OSCILLATOR FREQUENCY ADJUSTMENT

NOTE

Verify the i-f frequency (11.400000 MHz \pm 2 Hz) before performing local oscillator frequency adjustment.

Step 1. Turn the radio on and allow 15 minutes for the oven temperature to stabilize. The oven insulating cover must be on.

Step 2. Connect a wattmeter and a 50 ohm load to the antenna connector. Couple the frequency counter to the transmitter output using an in-line coupling unit (see Figure 2).

Step 3. Select a simplex channel and key the transmitter in the tune mode using the tune-up plug which grounds J10-3, of the 6-pin accessory connector (see Figure 3). Be sure that no audio input is present by removing the microphone connector.

Step 4. Using the insulated tuning tool adjust the frequency trimmer capacitor corresponding to the channel selected for a reading on the frequency counter equal to the assigned carrier frequency \pm 5 Hz. See Figure 4 for location of the trimmer capacitors.

Step 5. Repeat Step 4 for all simplex channels.

Step 6. Select a half-duplex channel and key the transmitter in the tune mode.

Step 7. Using the insulated tuning tool adjust the duplex frequency trim capacitor ("B" side of oven) corresponding to the channel selected for the assigned transmit carrier frequency \pm 5 Hz (see Figure 4).

Step 8. Program the selected half-duplex channel for SIMPLEX operation by opening the Duplex Programming switch that is associated with the selected channel. Be sure the "A/B" front panel switch is in the "A" position. This allows the radio to transmit in the tune mode on the receiver frequency.

Step 9. Key the radio in the tune mode and adjust the frequency trimmer capacitor ("A" side of oven) corresponding to the channel selected for the assigned receive frequency \pm 5 Hz.

Step 10 Return the radio to the proper duplex programming on the selected channel.

Step 11. Repeat Steps 6, 7, 8, 9 and 10 for each duplex channel.

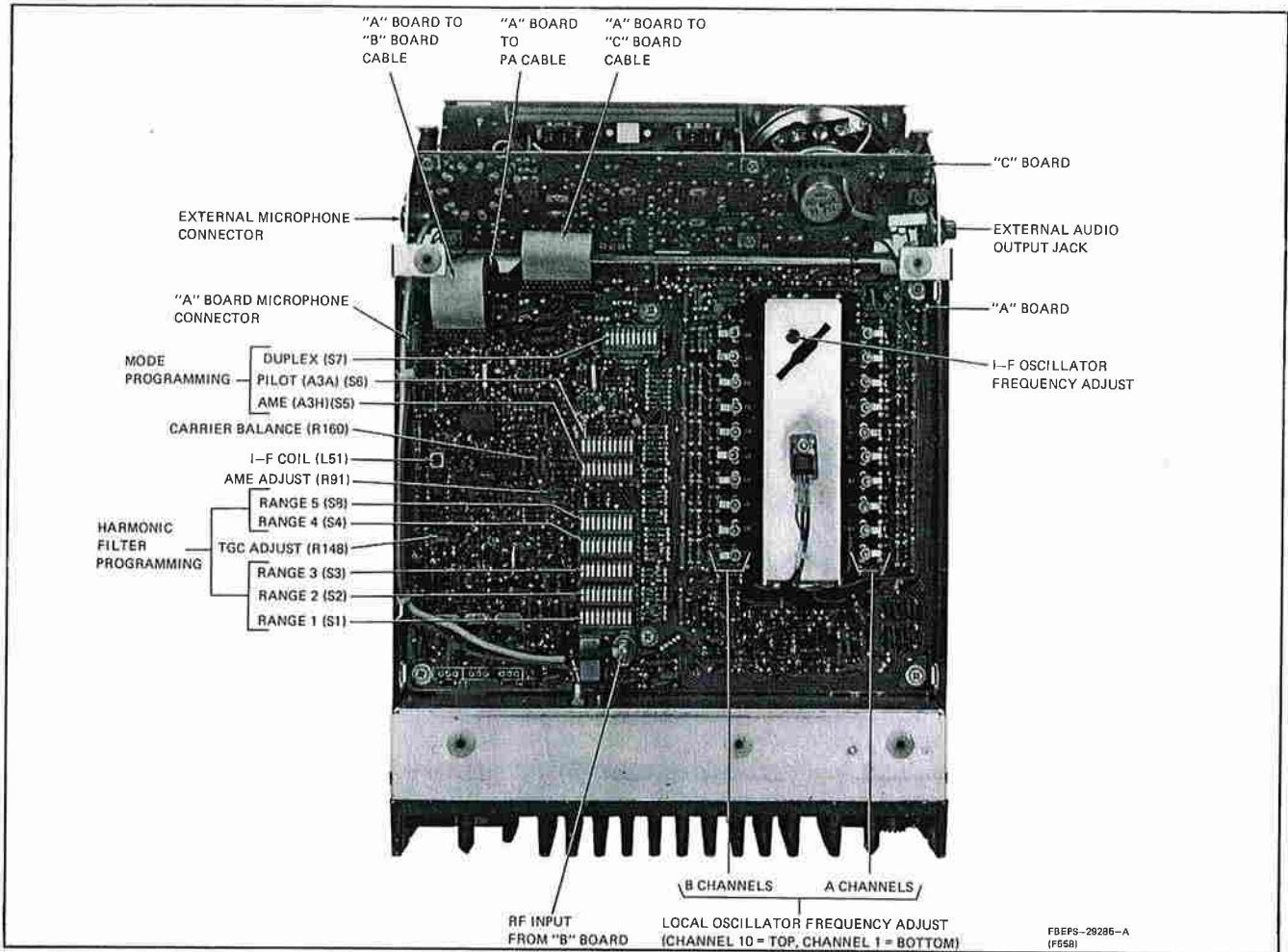

Figure 1. "A" Board Adjustments

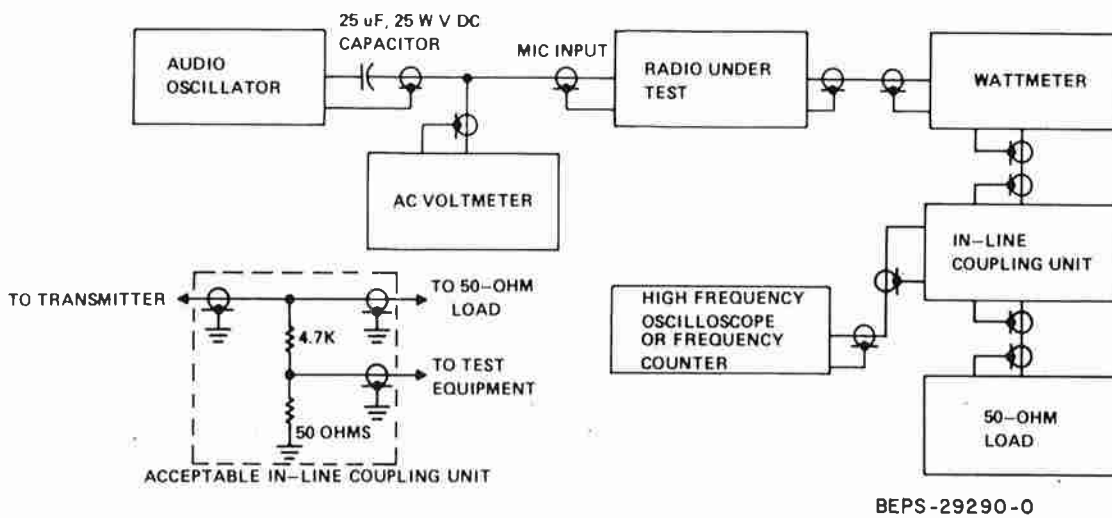

Figure 2. Test Equipment Set-Up

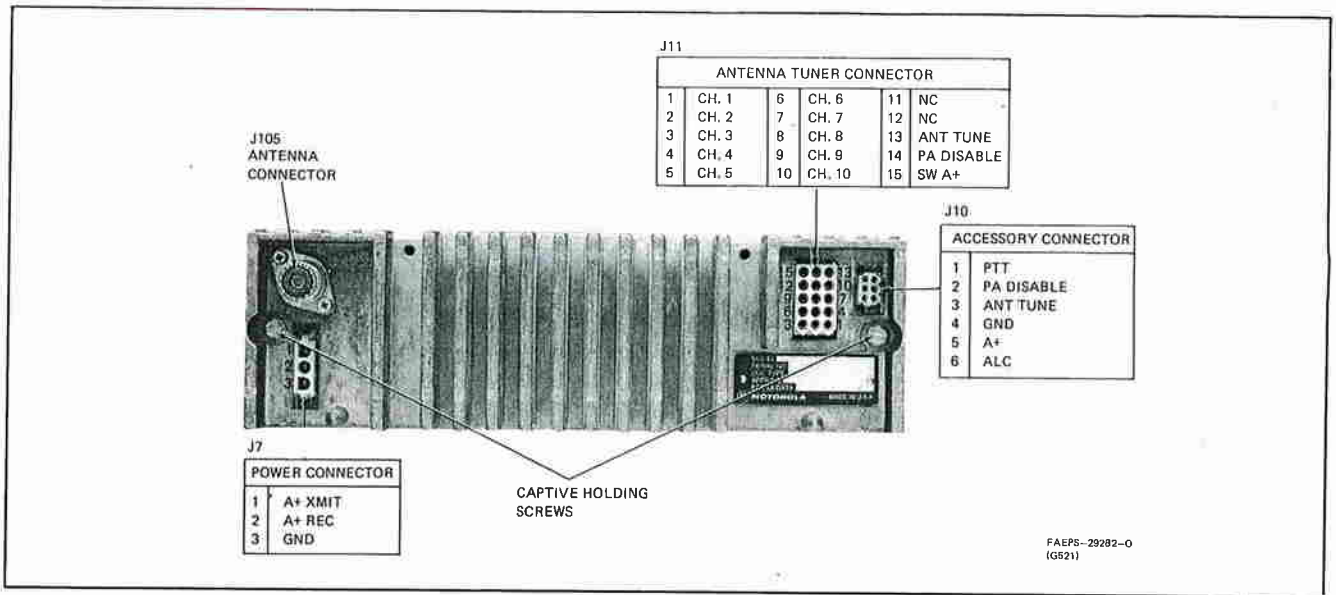

Figure 3. Rear External Connections

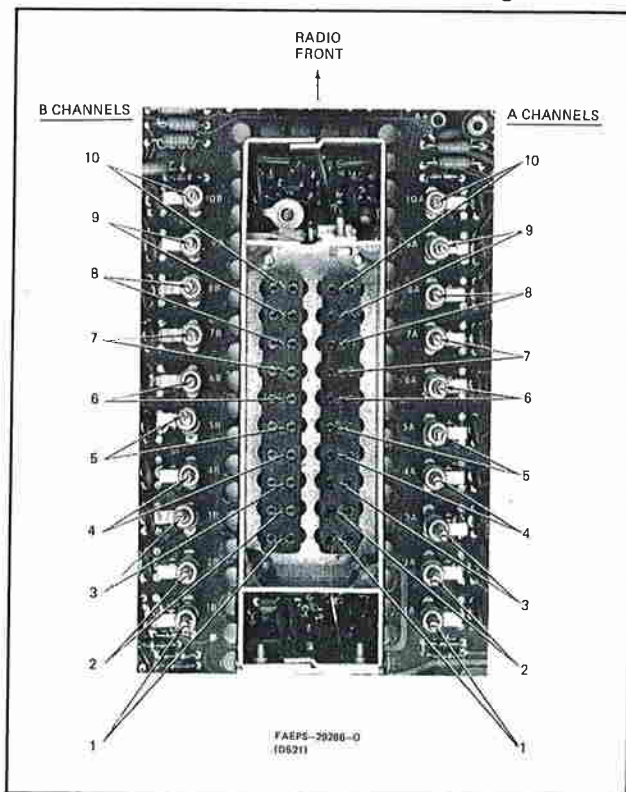

Figure 4. Local Oscillator Crystals and Trimmer Capacitor Locations

2. FACTORY PRESET ADJUSTMENTS

CAUTION

The following adjustments have been factory preset. Misalignment can adversely affect performance or cause serious damage. All procedures must be performed in the following order.

2.1 PRELIMINARY PROCEDURES

Step 1. Observe the following standard test conditions:

- Power supply voltage set at 13.4 V dc.
- Ambient temperature of 25 ± 5 degrees C.
- SSB (A3J) programmed mode unless otherwise stated.
- Wattmeter accurately calibrated.
- To ensure that the power amplifier is not overdriven, use the minimum microphone input level necessary to obtain the required output level. Until the TGC and ALC have been set, limit transmission time to the minimum required.

Step 2. Preset the following controls:
(Refer to Figure 1 and 5 for location details.)

CAUTION

Potentiometer preset position is described from the front (blue side) of the control.

- TGC — R148 ("A" board) fully counterclockwise.
- AME — R91 ("A" board) fully counterclockwise.
- ALC — R445 (PA) fully clockwise.
- TUNE — R441 (PA) fully clockwise.
- BIAS — R417 (PA) fully clockwise.
- CARRIER BALANCE — R160 ("A" board) centered.
- 11.4 MHz I-F NOTCH FILTER — L8, L9, L10 ("B" board) coil cores flush with top of can.
- RECEIVER I-F — L51 ("A" board) flush with top of can.
- MODE PROGRAMMING — S5, S6 ("A" board) switches all channels open.

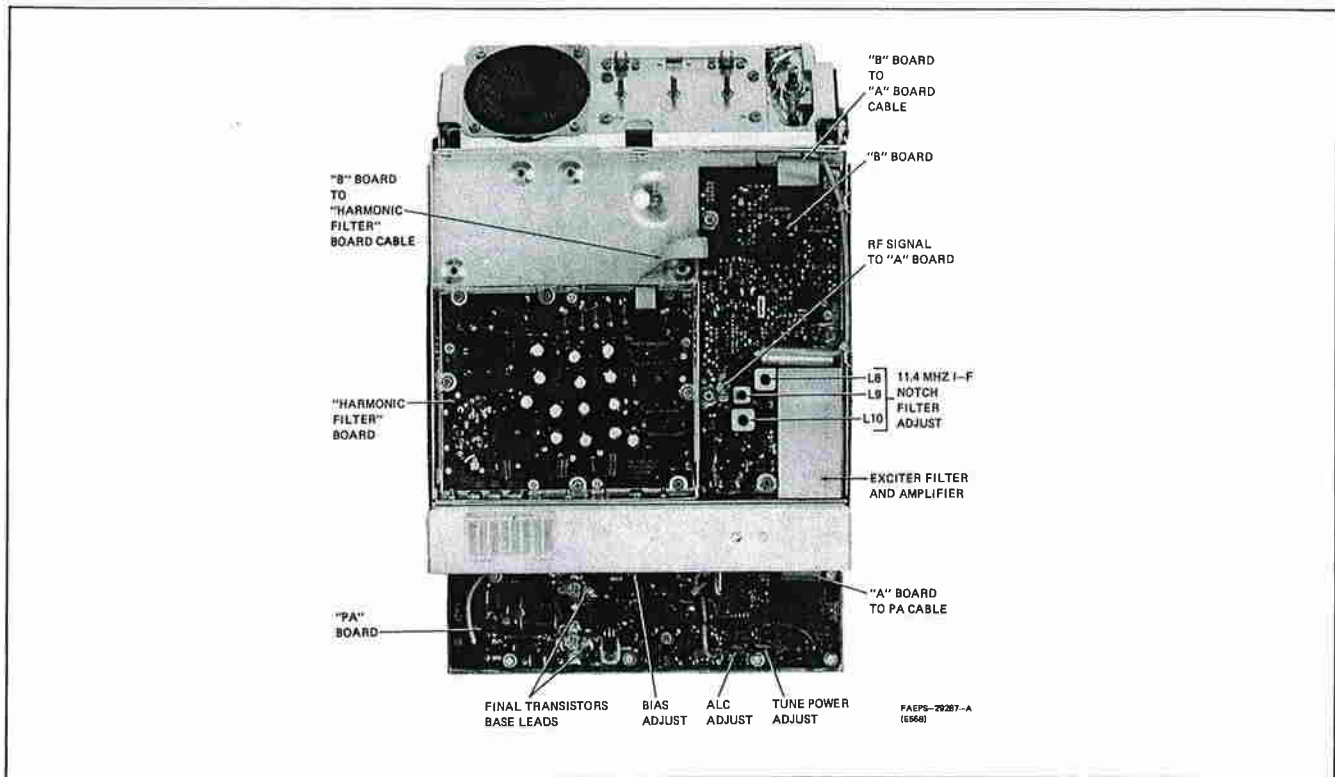

Figure 5. "B" Board and PA Adjustments

Step 3. Connect a wattmeter and 50-ohm load to the antenna jack. Couple an oscilloscope to the transmitter output using a coupling unit constructed as shown in Figure 2. Connect an audio oscillator to pins 1 (audio high) and 3 (ground) of the microphone connector.

Step 4. To key the transmitter in those procedures, short pin 2 (PTT) of the microphone connector to ground.

2.2 PA BIAS SET

Step 1. Be sure the PA heat sink temperature is $25 \pm 5^\circ\text{C}$ and that no audio input is present at the microphone input.

Step 2. Key the radio in the SSB (A3J) mode on any channel.

Step 3. Monitor the base voltage of one of the final amplifier transistors, Q408 or Q409. Adjust BIAS control pot R417 for a reading of .63 V dc.

2.3 TRANSMITTER GAIN CONTROL (TGC) SET

Step 1. Connect a 1 kHz tone from the audio oscillator to the microphone input connector.

Step 2. Key the transmitter on any channel in the SSB (A3J) mode and adjust the audio input so that the power output is 50 watts.

Step 3. Leaving the audio input fixed, rotate through all channels and select both USB and LSB while noting the power output level. The channel with the lowest output power is the lowest gain channel.

Step 4. Select the lowest gain channel (lowest power output) and adjust the audio input to 300 mV ac.

Step 5. Rotate the TGC control (R148) until the power output is 115 watts.

2.4 AUTOMATIC LEVEL CONTROL (ALC) SET

Step 1. Select the highest frequency channel.

Step 2. Key the radio in the SSB (A3J) mode.

Step 3. Rotate the ALC control (R445) on the power amplifier until the power output is 105 watts. The power output on any channel should now be 100 ± 10 watts.

2.5 AME CARRIER SET

Step 1. Select the lowest gain channel as previously determined in Steps 3 and 4 of the TGC set.

Step 2. Program this channel for AME by closing the appropriate AME Programming switch associated with the lowest gain channel number.

Step 3. Apply a 300 mV ac audio signal at 1 kHz to the microphone connector.

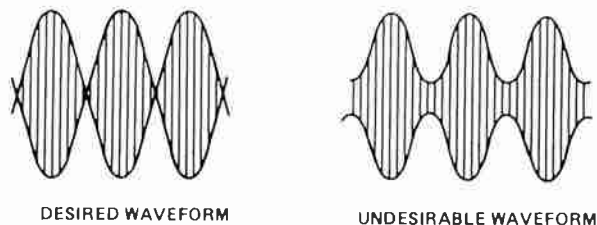

AEPS-29291-0

Figure 6. AME Waveform Adjustments

Step 4. With the oscilloscope connected as shown in Figure 6 adjust the AME control (R91) for the desired waveform shown in Figure 2. There must be no crossover distortion of the rf envelope.

2.6 TUNE MODE OUTPUT POWER SET

Step 1. Key the transmitter in the tune mode using the tune-up plug which grounds J10-3 of the 6-pin accessory connector on the PA heatsink.

Step 2. With no audio input signal, adjust the TUNE control (R441) on the power amplifier for 4 ± 1 watt rf output.

2.7 CARRIER BALANCE CONTROL

Step 1. Select any channel and ensure that it is programmed for SSB (A3J).

Step 2. Remove the audio input from microphone connector.

Step 3. Connect an oscilloscope as shown in Figure 2.

Step 4. Key the transmitter and observe the oscilloscope trace.

Step 5. Adjust the carrier balance control for a minimum rf level as viewed on the oscilloscope.

2.8 I-F NOTCH FILTER ADJUSTMENT

Step 1. Disconnect the "B" to PA board rf coax at the connector on the "B" board and attach an rf voltmeter to this point.

Step 2. Disconnect the "A" to "B" board rf coax at the connector on the "B" board, and apply an $11.400000 \text{ MHz} \pm 10 \text{ Hz}$, -20 dBm signal at this point.

Step 3. Key the transmitter and observe the level on the rf voltmeter.

Step 4. Tune L9, L8, and L10 in that order, for a minimum reading on the rf voltmeter. After adjusting each coil do not readjust.

2.9 RECEIVER I-F COIL ADJUSTMENT

Step 1. Be sure the transmitter is not accidentally keyed during the following procedure.

Step 2. Connect a signal generator to the antenna input connector and apply a 1 uV signal modulated with a 1 kHz tone at the selected frequency.

Step 3. Adjust the i-f coil (L51) for maximum audio level at the speaker.



1. GENERAL

The amplifier circuits in the radio are wideband amplifiers that eliminate the need for most tuning adjustments. Receiver selectivity and transmitter spurious emission attenuation are provided using switchable filters. Filter switching is performed using biased-diode type switches and highly reliable hermetically sealed reed relays.

The transmitter and receiver share a common intermediate frequency (11.4 MHz). They also share the use of the following common circuits: i-f mixer, notch filter, crystal filter, local oscillator mixer, bi-directional amplifiers, and harmonic filters. Dual in-line package (DIP) switches are used to program the appropriate filters depending on the operating frequency.

2. RECEIVE SIGNAL PATH

(Refer to the radio set block diagram.)

2.1 HARMONIC FILTER

Received signals from the antenna system are applied to the harmonic filter board. The harmonic filters provide rejection of frequencies above the filter range selected. In the receive mode, signals are coupled through the antenna relay to the front end bandpass filter on the "B" board.

2.2 "B" BOARD RECEIVE CIRCUITRY

The bandpass filter attenuates incoming receive signals that fall outside the operating frequency range of the radio. The output of the bandpass filter is applied to the receiver front end amplifier. The receive signal next is passed to the 11.4 MHz notch filter to provide attenuation of a received signal at the i-f frequency. From the notch filter the receive signal is connected, with a coax cable, to the local oscillator mixer on the "A" board.

The squelch circuitry is also contained on the "B" board. When no voice information is being received, the

squelch circuit generates an audio mute signal. This mute signal is applied to the "C" board to disable the audio at the speaker.

2.3 "A" BOARD RECEIVE CIRCUITRY

The local oscillator injection signal is derived from one of two local oscillator circuits. This signal is amplified by the L.O. injection amplifier and applied to the L.O. mixer. High side injection is used. The injection and received signal are mixed together to produce the 11.4 MHz i-f. The i-f signal is applied to the appropriate crystal filter through a bi-directional amplifier.

Most of the receiver selectivity is provided by the crystal filter. From the crystal filter, the signal is applied to the i-f amplifier through another bi-directional buffer amplifier.

The i-f amplifier provides most of the gain of the receiver. The gain of the i-f amplifier is controlled by the receiver gain control (RGC) circuitry to provide a fairly constant output for wide input signal variations. From the i-f amplifier the signal goes to the i-f mixer.

An 11.4 MHz oscillator provides the injection for the i-f mixer. The signal and injection are mixed together to provide the receive audio. In this way, the mixer functions as the SSB audio product detector. The receive audio is then applied to the audio pre-amplifier, then to the active filter.

2.4 "C" BOARD RECEIVER CIRCUITRY

The output of the active filter is applied through the ribbon cable to the volume control on the "C" board. From the volume control the signal goes to the audio amplifier stages and out to the 2-ohm speaker. The "C" board also contains the channel selector switch, A/B channel switch, squelch and clarifier controls, transmit and power-on lamps, dimmer switch, and external audio output jack.

3. TRANSMIT SIGNAL PATH

3.1 "A" BOARD CIRCUITRY

Transmit audio from the microphone is applied to an audio amplifier and onto the i-f mixer. The transmit gain control (TGC) senses the output level of the transmit i-f signal and varies an attenuator at the input of the audio amplifier to maintain a nearly constant level of audio into the i-f mixer.

The i-f injection and transmit audio are applied to the i-f mixer where the output is an 11.4 MHz suppressed carrier double sideband signal. This signal is applied to the crystal filter through the bi-directional buffer amplifier. The crystal filter strips off the unwanted sideband and the desired sideband is then applied to the L.O. mixer through the bi-directional buffer amplifier. Also, at this point, 11.4 MHz carrier is re-inserted if either AME or pilot is programmed.

The L.O. mixer takes the local oscillator injection and sideband signal and converts the sideband signal to the operating frequency. From the output of the mixer, the signal goes through a coax cable to the notch filter on the "B" board.

3.2 "B" BOARD TRANSMITTER CIRCUITRY

The notch filter removes any 11.4 MHz frequency component from the signal. The signal then goes to the exciter filter which attenuates any components above the highest carrier frequency. From here the signal is applied to a 2 stage exciter amplifier. The output of the exciter is routed by coax cable to the PA input.

3.3 PA BOARD CIRCUITRY

The exciter output is amplified to the rated power level by the power amplifier and applied to the harmonic filter (HF) board.

The PA board also contains automatic level control (ALC) circuitry to ensure proper PA operation and protection. ALC circuitry monitors forward and reflected power levels (from a VSWR detector on the harmonic filter board), and heatsink temperature. Power is reduced if either:

- a. heat sink temperature becomes excessive,
- b. forward power is low (possibly indicating excessive harmonic filter loss due to improper programming), or
- c. reverse power is excessive.

The ALC circuit can also switch the power amplifier to a low power mode (4 watts) when a ground is applied to J10 pin 3. This is an appropriate level for antenna tuner adjustments.

3.4 HF BOARD CIRCUITRY

From the PA the transmit signal is routed to the harmonic filter. The harmonic filter consists of four separate filters, each covering a portion of the entire transmitter frequency range. The appropriate filter is selected by sealed relays which are controlled by the range programming switches.

From the harmonic filter, the transmit signal is applied to the antenna relay and routed to the antenna connector.

4. REFERENCE DIAGRAMS

"A" Board

Circuit Board Detail . . . PEPS-31351 (Sheet 1 of 3)

Schematic Diagram (Sheet 2 of 3)

Schematic Diagram (Sheet 3 of 3)

"B" Board

Circuit Board Detail PEPS-29297

Schematic Diagram EEPS-29109

"C" Board

Circuit Board Detail PEPS-29303

Schematic Diagram DEPS-29133

Harmonic Filter Board

Circuit Board Detail PEPS-29299

Schematic Diagram DEPS-29097

Power Amplifier Board

Circuit Board Detail PEPS-29305

Schematic Diagram EEPS-29101

Intercabling Diagram EEPS-29138

From the harmonic filter, the transmit signal is applied to the antenna relay and routed to the antenna connector.

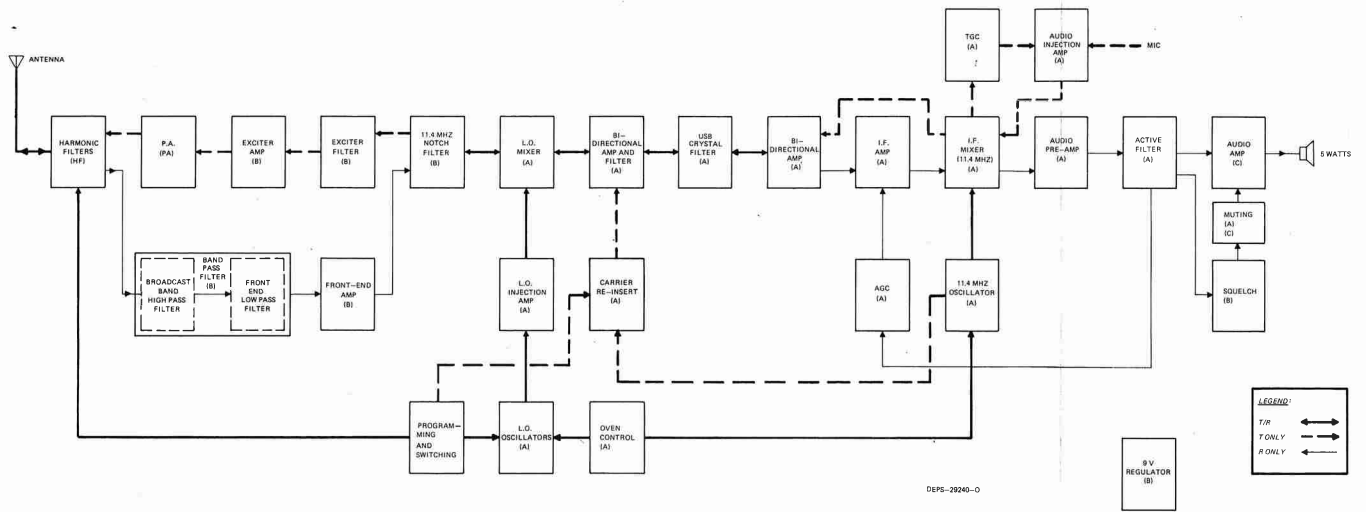

Figure 1. Radio Block Diagram

"A" BOARD
MODEL TRN4586A

DESCRIPTION

Check 1st. Doc.
R164 →

see note 1)
see note 1)
filter
Integrated circuits must be
refer to the Mechanical

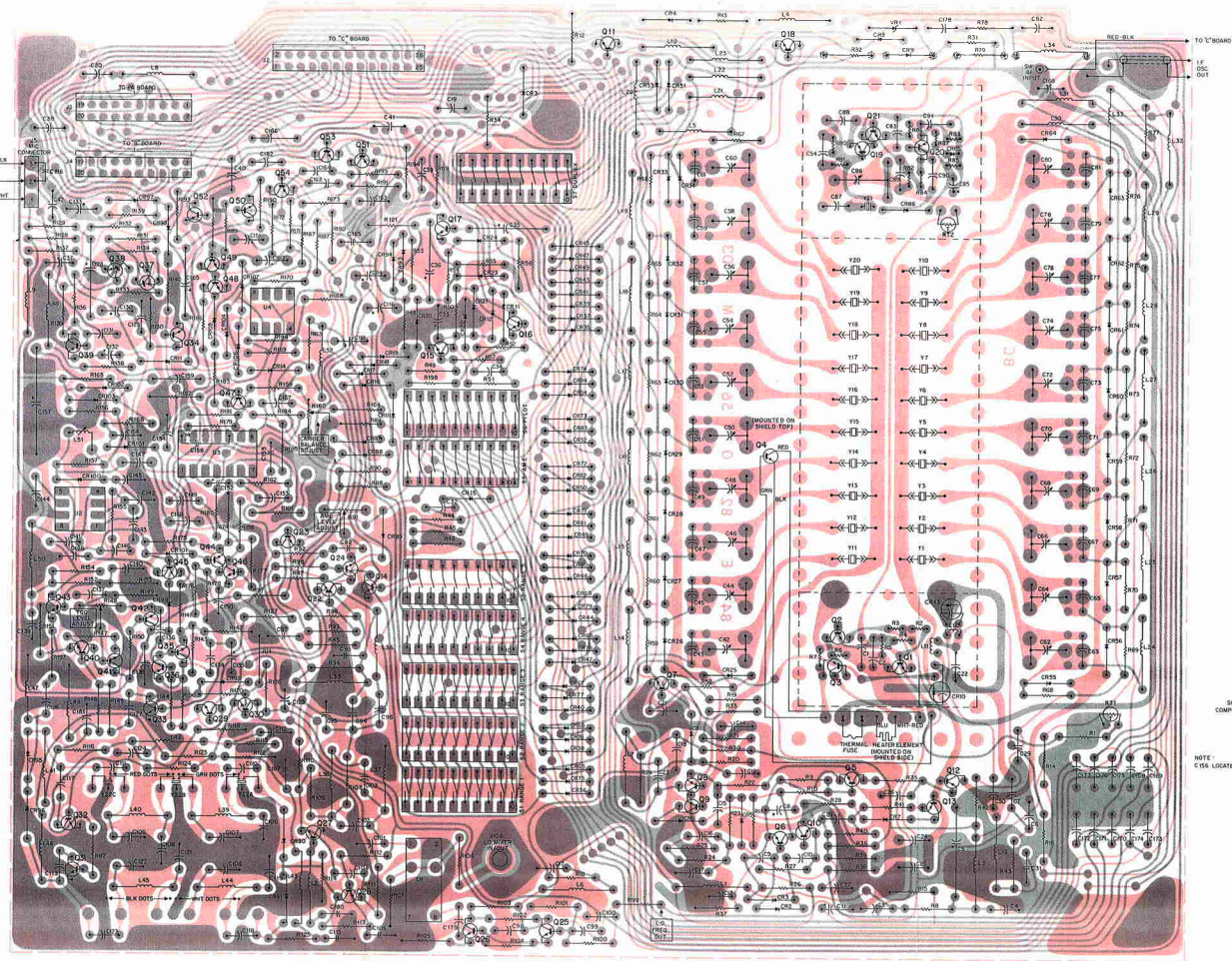

SOLDER SIDE: 80-EPSP-3155-0
COMPONENT SIDE: 80-EPSP-3155-0
OVERLAY: 01-EPSP-3154-0

NOTE: C85 LOCATED ON SOLDER SIDE.

Motorola No. PEPS-3151-O
(Sheet 1 of 3)
12/15/80-PHI

"A" BOARD

"A" BOARD
MODEL TRN4586A

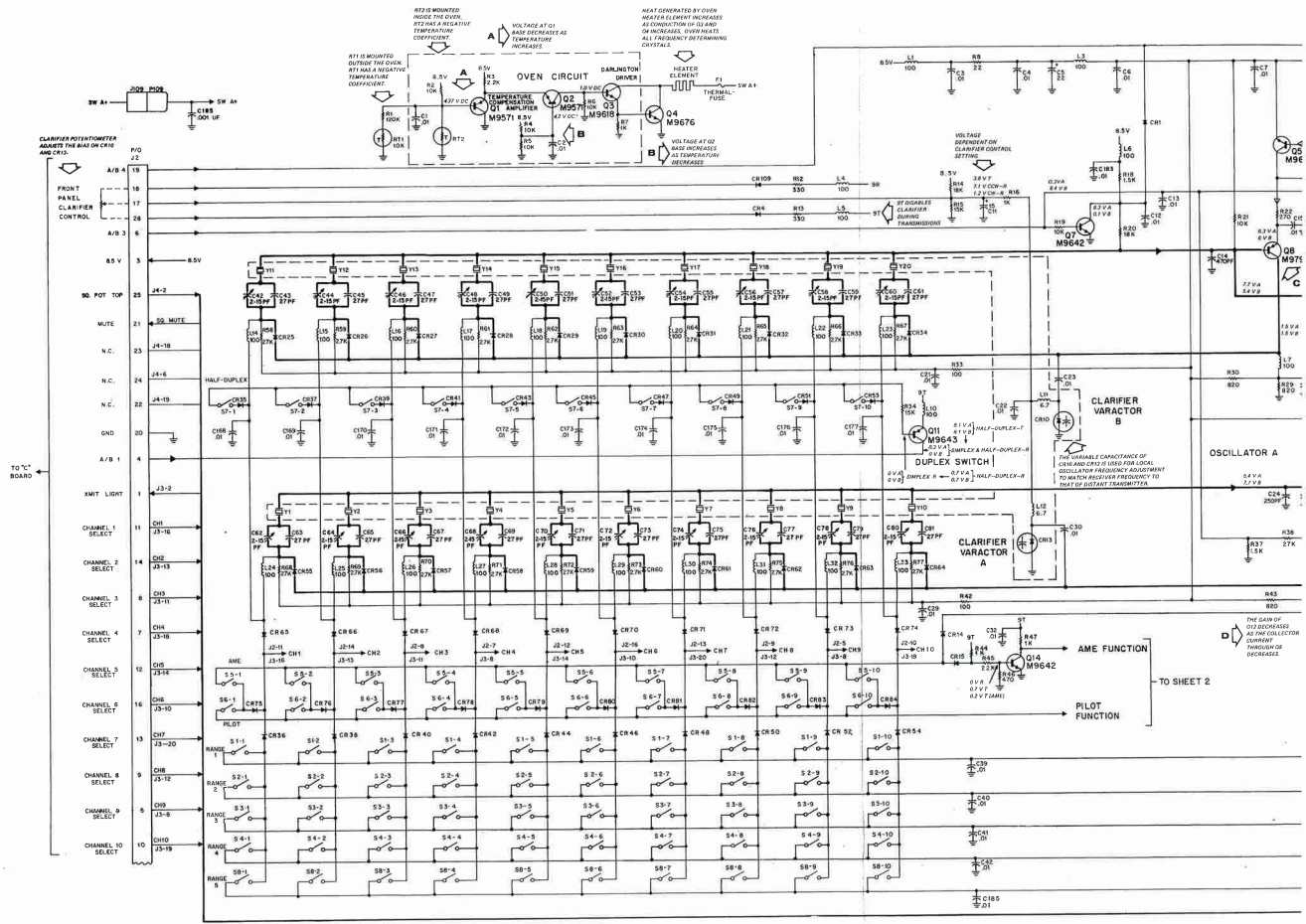

Motorola No. PEPS-31351-O
(Sheet 2 of 3)
12/15/80-PH1

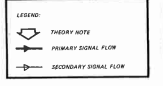
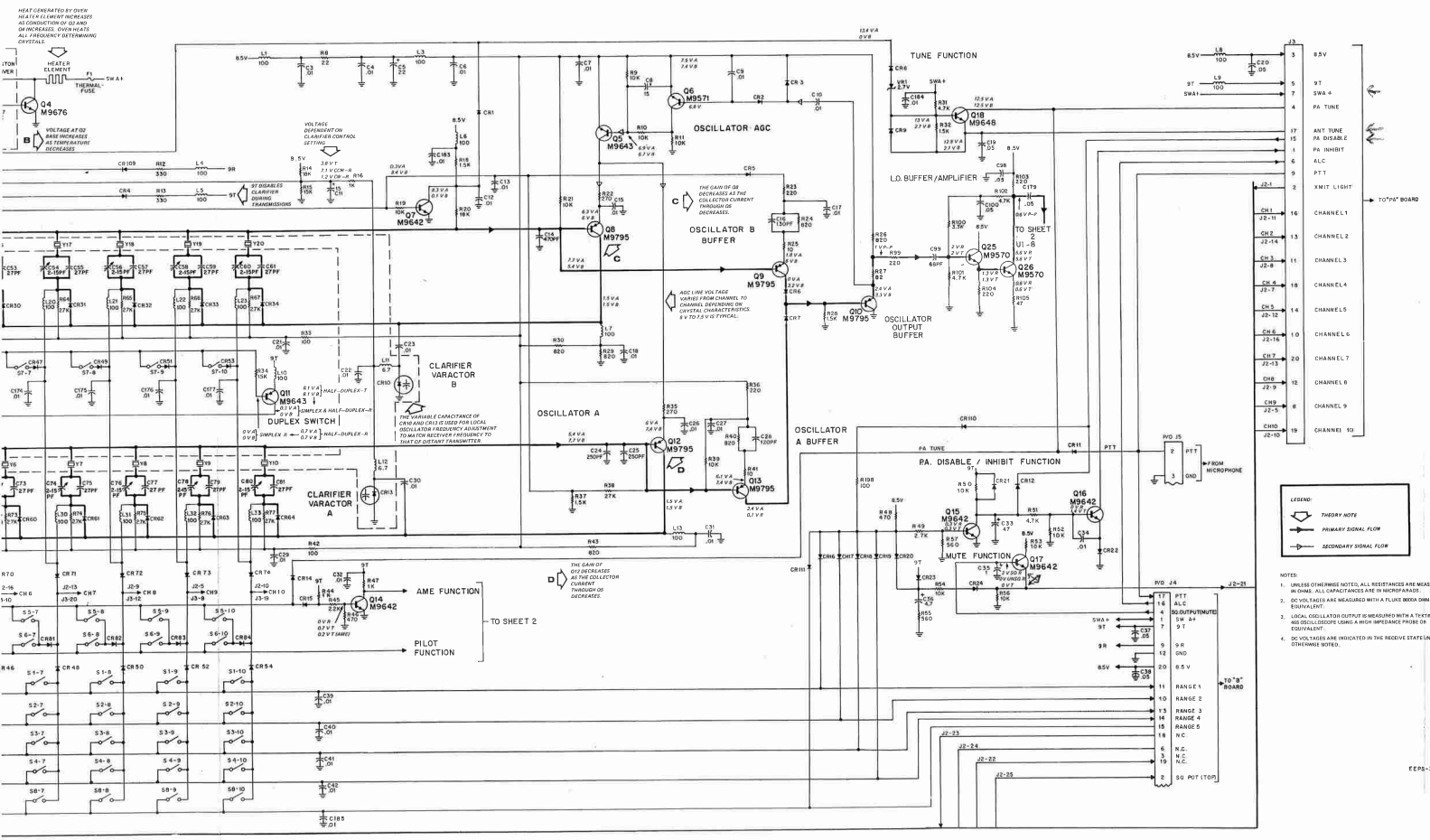

- NOTES:
- UNLESS OTHERWISE NOTED, ALL RESISTANCES ARE MEASURED IN OHMS. ALL CAPACITANCES ARE IN MICROFARADS.
 - DC VOLTAGES ARE MEASURED WITH A PLICE BROWN OHMMETER EQUIVALENT.
 - LOCAL OSCILLATOR OUTPUT IS MEASURED WITH A TESTMETER AND SHOULD BECOME USING A HIGH IMPEDANCE PROBE OR EQUIVALENT.
 - DC VOLTAGES ARE INDICATED IN THE RECEIVE STATE UNLESS OTHERWISE NOTED.

"A" BOARD
MODEL TRN4586A

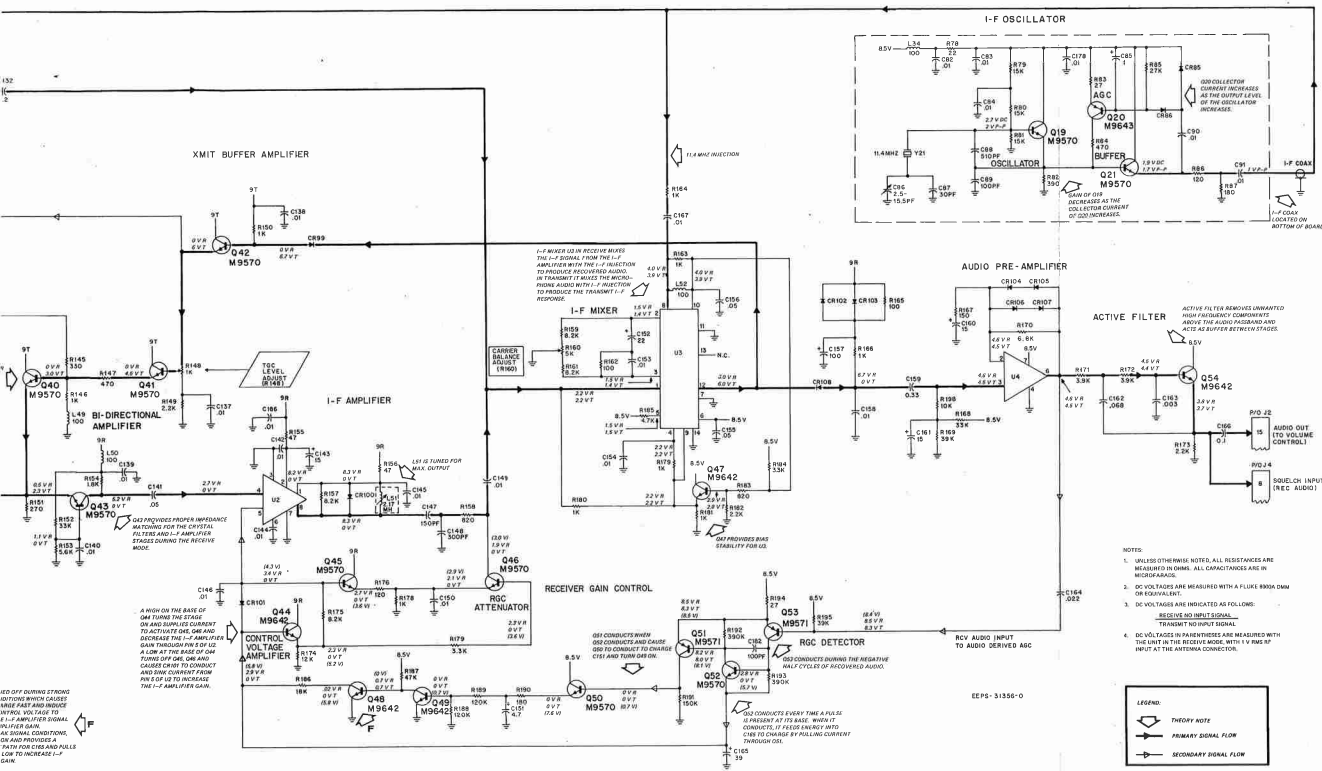

- NOTES:
1. UNLESS OTHERWISE NOTED, ALL RESISTANCES ARE MEASURED IN OHMS. ALL CAPACITANCES ARE IN MICROFARADS.
 2. DC VOLTAGES ARE MEASURED WITH A FLUXE 8908C DMM OR EQUIVALENT.
 3. DC VOLTAGES ARE INDICATED AS FOLLOWS:
RESIDUE AND MULTIPLE SIGNALS: TRANSMIT (T) OR RECEIVE (R) SIGNAL.
 4. DC VOLTAGES IN PARENTHESSES ARE MEASURED WITH THE UNIT IN THE RECEIVE MODE, WITH A 100 OHM INPUT AT THE ANTENNA CONNECTOR.

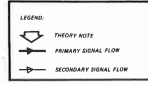

Motorola No. PEPS-31351-O
(Sheet 3 of 3)
12/15/80-PHI

"A" BOARD

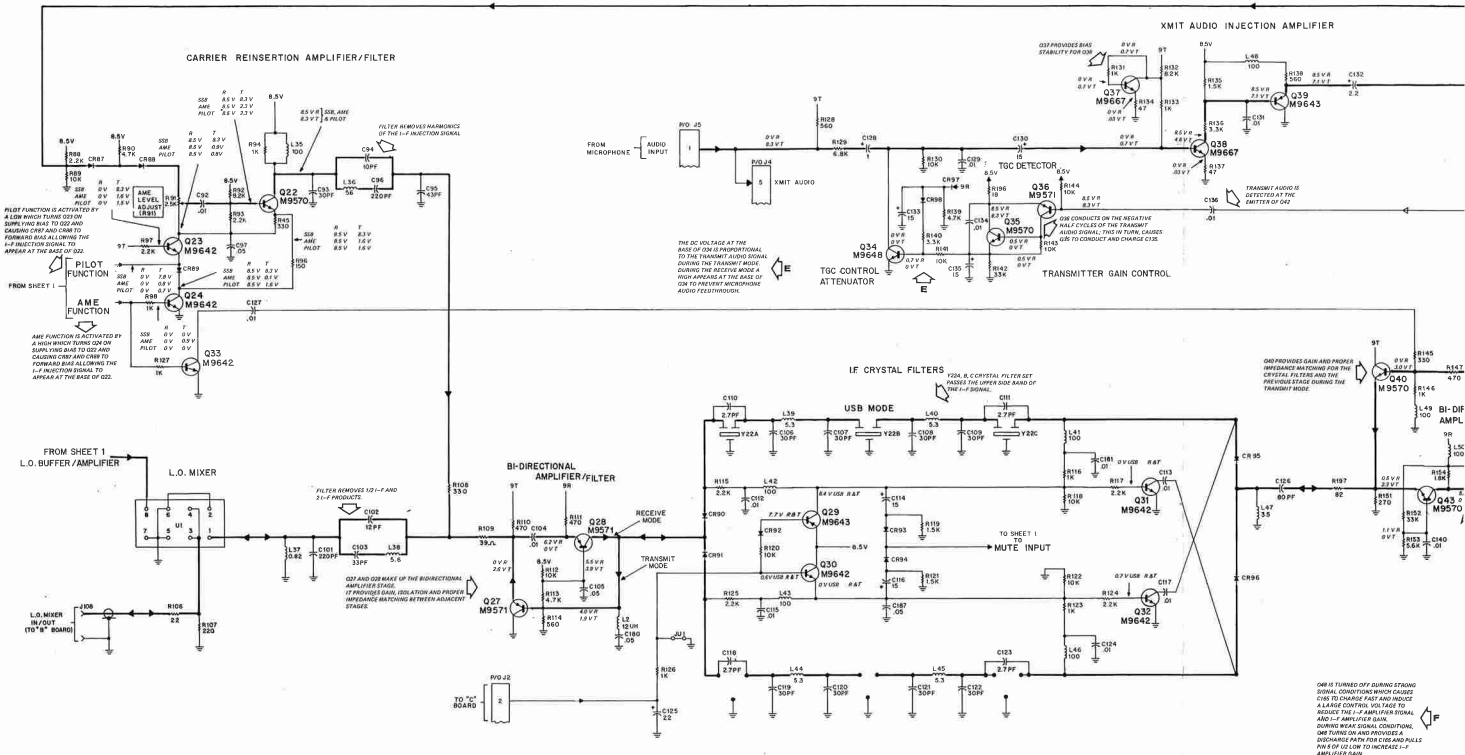

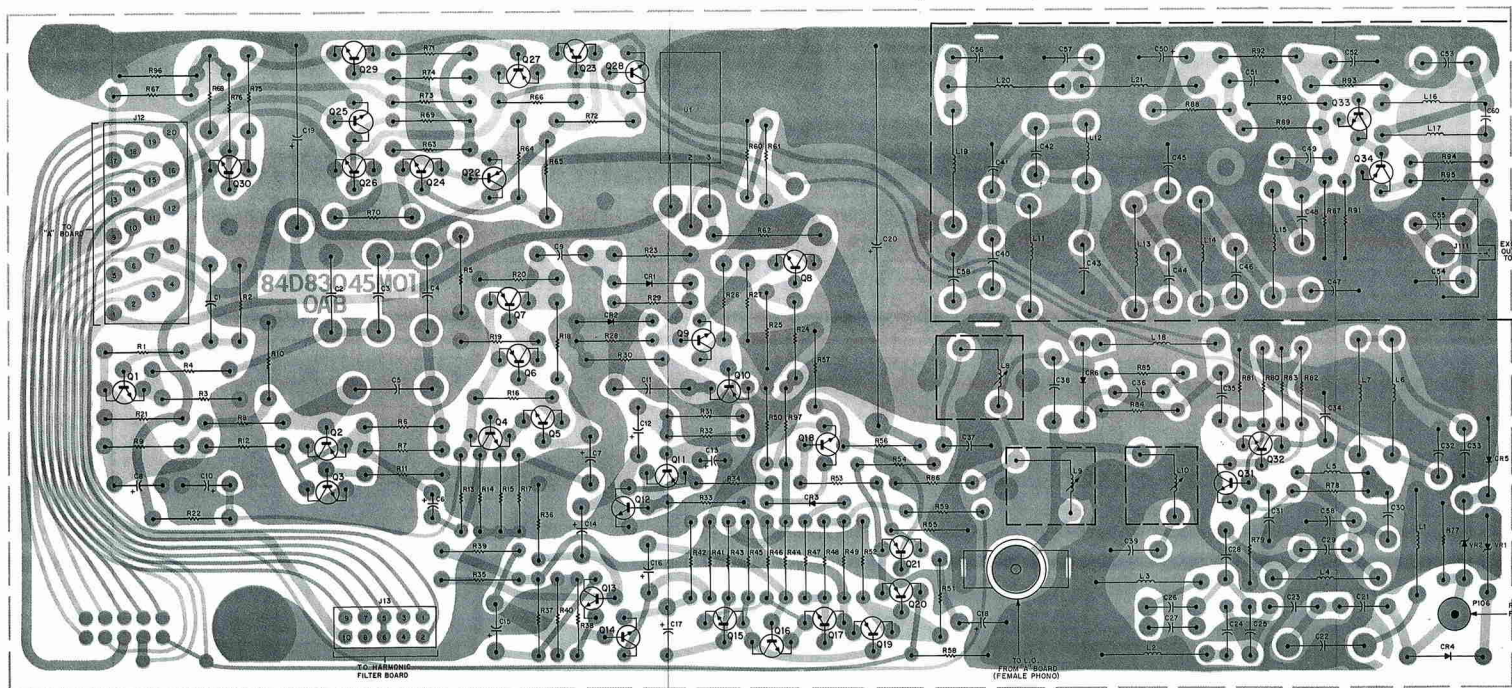

SHOWN FROM COMPONENT SIDE

COMPONENT SIDE □ 00-DEPS 29110-0
 SOLDER SIDE ■ 8D-DEPS 29111-0
 OVERLAY ○ L-EEPS 29112-A

parts list

TRN4035B "B" Board PL-6757-A

REFERENCE SYMBOL	MOTOROLA PART NO.	DESCRIPTION	REFERENCE SYMBOL	MOTOROLA PART NO.	DESCRIPTION
		capacitor, fixed, $\pm 10\%$ unless otherwise stated:			resistor, fixed, $\pm 10\%$; 1/4 W unless otherwise stated:
C1	8-8209J05	.088; 250 V	R1, 2	6-124C89	47k
C2 thru 5	8-8313H15	.015 $\pm 5\%$; 50 V	R3	6-124C57	2.2k
C6	23-84538G14	1.0; 35 V	R4	6-124C91	3.3k
C7, C14-C17	23-84538G26	4.7 $\pm 20\%$; 10 V	R5	6-124A77	15k $\pm 5\%$
C8	23-84538G26	33; 10 V	R6, 7	6-124A75	12k $\pm 5\%$
C9	21-82187B20	.001; 100 V	R8	6-124A86	91k $\pm 5\%$
C10	23-84538G26	33; 10	R9, 10	6-124A82	24k $\pm 5\%$
C11	8-84537L06	.0088 $\pm 5\%$; 630 V	R11	6-124C73	10k
C12	23-84538G27	2.2; 25 V	R12	6-124C95	4.7k
C18	23-84538G27	2.2; 25 V	R13, 14	6-124C89	47k
C19	23-84668A19	100 $\pm 10\%$; 20 V	R15	6-124C57	2.2k
C20	23-83210A24	1000 $\pm 10\%$; 20 V	R16	6-124C45	500
C21	21-82187B20	.003; 100 V	R17	6-124B55	2.7 $\pm 5\%$
C22	8-83813H15	.015 $\pm 5\%$; 50 V	R18	6-124A87	100k $\pm 5\%$
C23	21-82187B31	.0015; 100 V	R19, 20	6-124C89	6.8k
C24	21-82426B07	.0033; 200 V	R21	6-124C41	410
C25	21-82187B31	.0015; 100 V	R22	6-124C26	100
C26, 28	21-82187B26	.003; 100 V	R23	6-124C85	33k
C27	21-82187B31	.0015; 100 V	R24	6-124A81	56k $\pm 5\%$
C29, 30	21-84493B14	88 pF $\pm 5\%$; 200 V	R25	6-124A75	12k $\pm 5\%$
C31 thru 36	21-82372C10	.05 $\pm 20\%$; 25 V	R26	6-124C85	33k
C37	21-82204B46	30 pF $\pm 2\%$; 500 V	R27	6-124C57	2.2k $\pm 5\%$
C38	21-84857K11	180 pF $\pm 1\%$; 100 V	R28, 29	6-124A81	22k $\pm 5\%$
C39	21-82204B46	30 pF $\pm 2\%$; 500 V	R30	6-124C21	3.3k
C40	21-82372C10	.05 pF $\pm 5\%$; 500 V	R31, 32	6-124A85	33k $\pm 5\%$
C41	21-84494B83	170 pF $\pm 3\%$; 500 V	R53	6-124C73	10k
C42	21-8383M10	230 pF $\pm 1\%$; 500 V	R34	6-124C49	1k
C43	21-84494B83	170 pF $\pm 3\%$; 500 V	R35	6-124C83	27k
C44	21-84857K44	190 pF $\pm 2\%$; 500 V	R36	6-124A75	12k $\pm 5\%$
C45	21-84494B83	170 pF $\pm 3\%$; 500 V	R37	6-124A57	2.2k $\pm 5\%$
C46	21-82372B46	100 pF $\pm 1\%$; 500 V	R38	6-124A49	1k $\pm 5\%$
C47	21-82372B26	200 pF $\pm 1\%$; 500 V	R39	6-124C81	22k
C48, 49	21-82372C10	.05; 25 V	R40	6-124A75	12k $\pm 5\%$
C50	23-84538G22	4.7; 20% 20 V	R41, 42	6-124A57	2.2k $\pm 5\%$
C51, 52	21-82372C10	.05; 25 V	R43, 44	6-124C85	33k
C53	21-82372B46	100 pF $\pm 1\%$; 500 V	R45	6-124C97	100k
C54	21-82372B26	200 pF $\pm 1\%$; 500 V	R46	6-124C75	12k
C55	21-83352J2	.02	R47	6-124A71	8.2k $\pm 5\%$
C56	21-83352J1	.01 $\pm 30\%$; 200 V	R48	6-124A81	27k $\pm 5\%$
C57	21-82372C10	.05 $\pm 20\%$; 25 V	R49	6-124A85	12k $\pm 5\%$
C58	21-84494B15	300 $\pm 5\%$; 500 V	R50	6-124A89	6.8k $\pm 5\%$
C59	21-84494B16	330 pF $\pm 5\%$; 500 V	R51	6-124C57	2.2k
C60	21-83406D04	19 pF $\pm 2\%$; 500 V	R52	6-124B14	470k $\pm 5\%$
		diode: (see note 1)	R53	6-124A81	56k $\pm 5\%$
CR1, 2, 3	48-83054H01	silicon	R55	6-124C85	33k
CR4, 5	48-82466H13	silicon	R56	6-124C89	47k
CR6	48-83654H01	silicon	R57	6-124A81	22k $\pm 5\%$
		connector, receptacle	R58	6-124C89	47k
J12	28-83570M03	p10 20-conductor cable	R59	6-124C95	4.7k
J13	28-83570M03	male, 10-contact	R60	6-124A19	56 $\pm 5\%$
J106	29-859943	terminal pin	R61	6-124A49	1k $\pm 5\%$
J107	9-82015F01	phono, .38" dia.	R62	6-125D70	1; 1/2 W
J111	9-83250M01	phono	R63	6-124C97	100k
L1	24-82635C34	4.4 uH	R64	6-124B04	180k $\pm 5\%$
L2, 3	24-82723H06	6.2 uH	R65, 66	6-124C81	22k
L4	24-82835C36	57 uH	R67	6-124C71	8.2k
L5	24-82723H05	4.1 uH	R68	6-124C49	1k
L6, 7	24-82549D41	190 uH	R69	6-124C91	22k
L8	24-84416Z00	33-1/2 turns	R70	6-124A55	1.8k $\pm 5\%$
L9	24-83308M01	4-1/2 turns	R71	6-124C97	100k
L10	24-84416Z00	33-1/2 turns	R72	6-124A81	22k $\pm 5\%$
L11	24-82835C33	1.1 uH	R73	6-124B04	180k $\pm 5\%$
L12	24-84389B11	15-1/2 turns	R74	6-124C91	22k
L13	24-82835C34	0.84 uH	R75	6-124A55	1.8k $\pm 5\%$
L14	24-82835C33	1.1 uH	R76	6-124C49	1k
L15, 16	24-82835C25	1.5 uH	R77	6-124C97	100k
L17	24-82835C31	5.2 uH	R78	6-124A07	18 $\pm 5\%$
L18, 19, 20	24-82549D41	190 uH	R79	6-124A33	200 $\pm 5\%$
L21	24-83981B01	3 turns	R80	6-124A81	3.3k $\pm 5\%$
		connector, plug:	R81	6-124A49	1k $\pm 5\%$
P12		p10 20-conductor cable	R82	6-124C45	680
		transistor: (see note 1)	R83	6-124A29	150 $\pm 5\%$
Q1	48-869642	NPN; type M9542	R84	6-124A45	680 $\pm 5\%$
Q2	48-869643	PNP; type M9543	R85	6-124A13	33 $\pm 5\%$
Q3, 4, 5	48-869642	NPN; type M9542	R86	6-124A25	100 $\pm 5\%$
Q6, 7	48-869643	PNP; type M9543	R87	6-124A21	68 $\pm 5\%$
Q8, 9	48-869642	NPN; type M9542	R88	6-124A87	5.6k $\pm 5\%$
Q10, 11	48-869643	PNP; type M9543	R89	6-124A89	6.8k $\pm 5\%$
Q12 thru 17	48-869642	NPN; type M9542	R90	6-124A85	33k $\pm 5\%$
Q18	48-869570	NPN; type M9570	R91	6-124A45	680 $\pm 5\%$
Q19, 20, 21	48-869643	PNP; type M9543	R92	6-124A45	680 $\pm 5\%$
Q22	48-869649	PNP; type M9549	R93	6-124A33	220 $\pm 5\%$
Q23	48-869642	PNP; type M9542	R94	6-124A11	27 $\pm 5\%$
Q24, 25, 26	48-869642	NPN; type M9542	R95	6-124A45	680 $\pm 5\%$
Q27	48-869649	PNP; type M9549	R96	6-124A09	22 $\pm 5\%$
Q28, 29, 30	48-869642	NPN; type M9542	R97	6-124C49	1k
Q31, 32	48-869570	NPN; type M9570	R98	6-124A85	33k $\pm 5\%$
Q33	48-869785	PNP; type M9785			integrated circuit: (see note 1)
Q34	48-869662	NPN; type M9662	U1	51-84621K25	type MC7808

notes:

- 1. For optimum performance, diodes, transistors, and integrated circuits must be ordered by Motorola part numbers.
- 2. For "B" Board parts list not listed in the above parts list, refer to the Mechanical Parts List.

"B" BOARD
MODEL TRN4035B

SQUELCH CIRCUIT

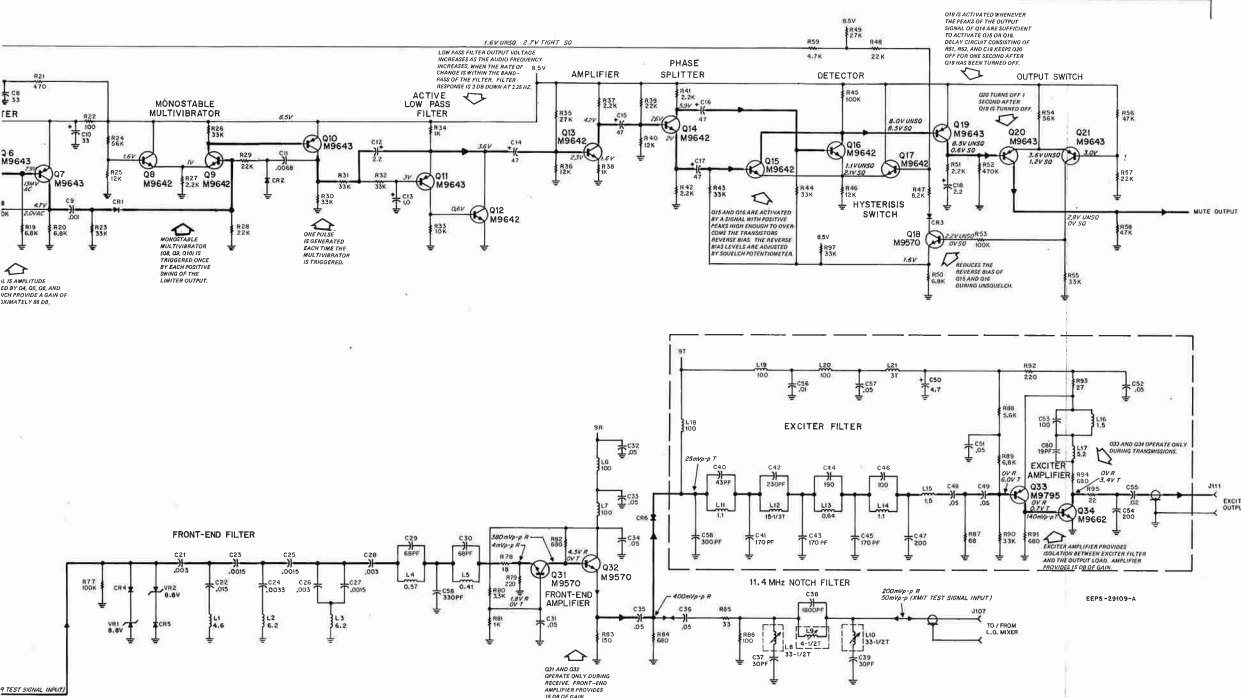

- NOTE:
- UNLESS OTHERWISE NOTED ALL RESISTOR VALUES ARE IN OHMS, CAPACITOR VALUES ARE IN MICROHMS, AND INDUCTOR VALUES ARE IN MICROHMS.
 - DC VOLTAGES ARE MEASURED WITH A FLUX SWEEP DMM.
 - EXCITER AMPLIFIERS ARE MEASURED WITH A 50 MV-P-P, 500 KHZ TEST SIGNAL AND A 50 MV-P-P, 500 KHZ WAVE TEST SIGNAL APPLIED AT THE RF RECEPTOR INPUT AND EXCITER OUTPUT PORTS RESPECTIVELY. A VECTORIAL OSCILLOSCOPE IS USED FOR THESE MEASUREMENTS.
 - RF VOLTAGES ON Q1 THROUGH Q10 ARE MEASURED WITH A 1 KHZ, 200 AC TEST SIGNAL AT THE INPUT. READINGS ARE RMS VALUES. A FLUX SWEEP DMM IS USED FOR THESE MEASUREMENTS.

TEST SIGNAL INPUT

"B"/"C" BOARD

Motorola No. EEP5-29109-A
12/15/80-PH1

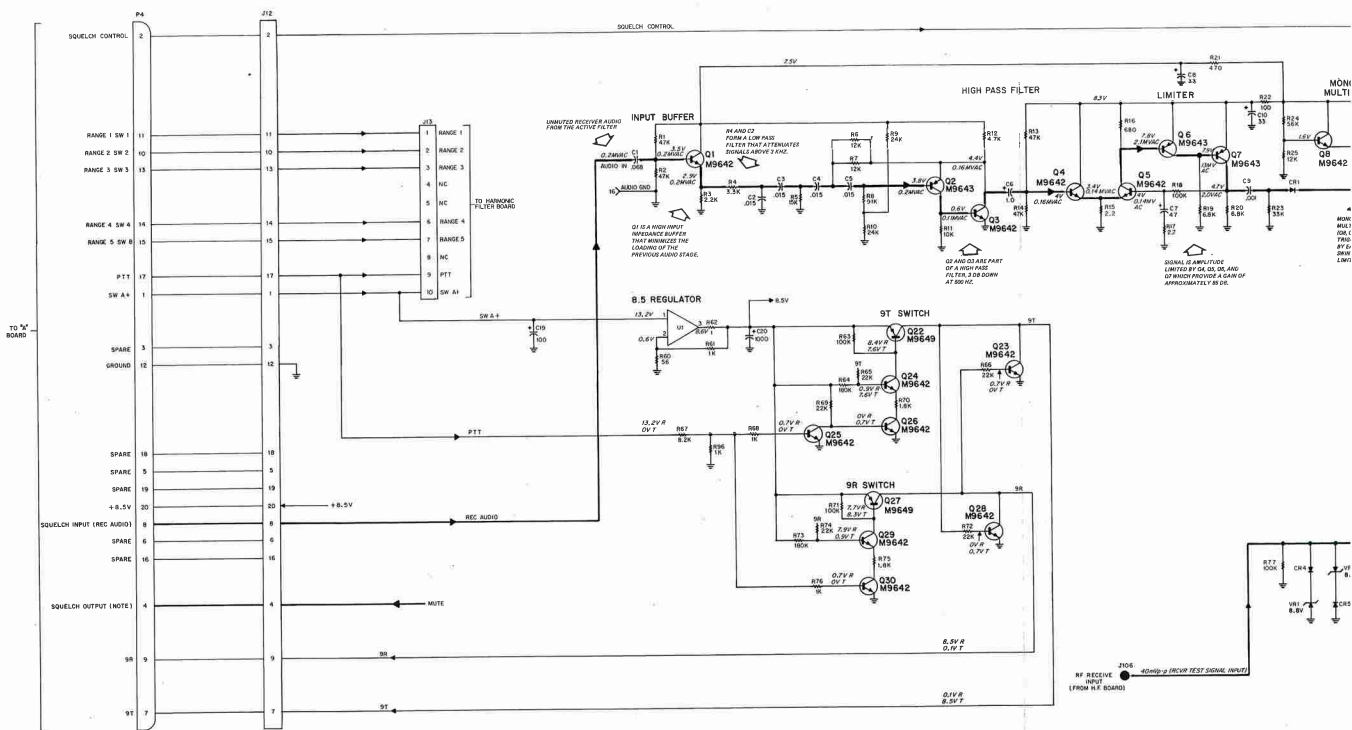

"C" BOARD
MODEL TRN4036A

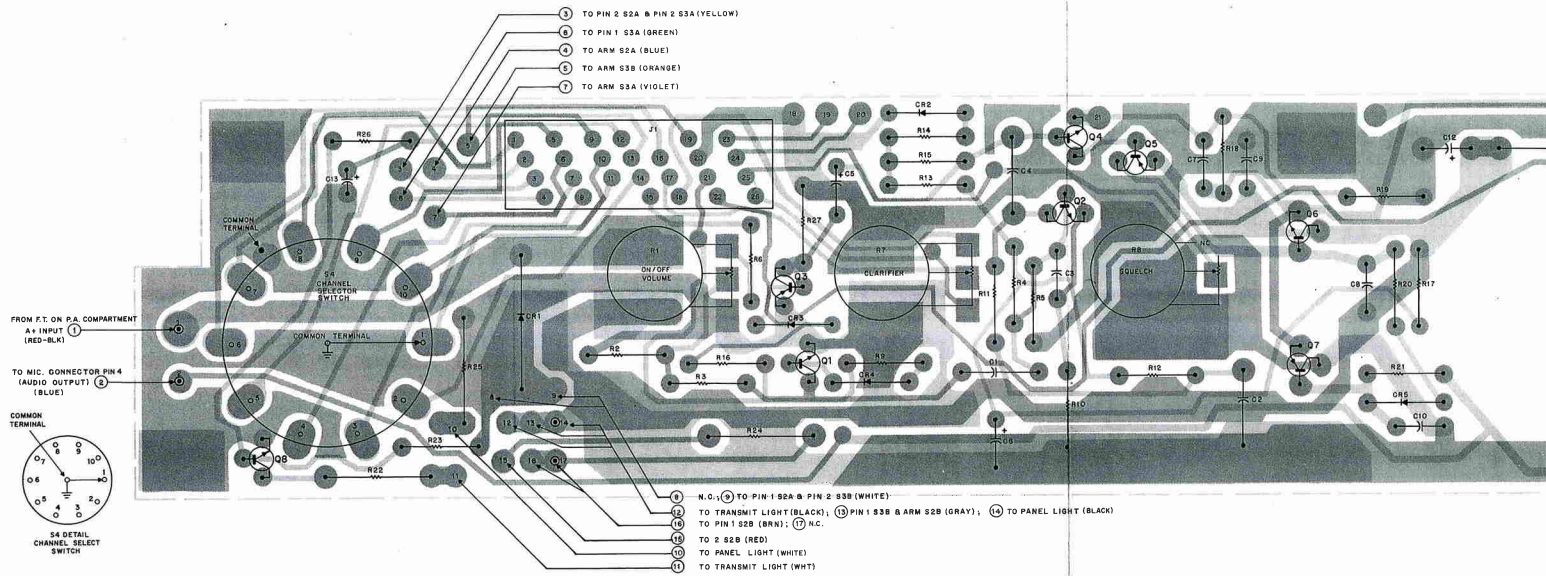

SHOWN FROM COMPONENT SIDE

Motorola No. PEPS-29303-A
12/15/80-PHI

parts list

TRN4036A "C" Board PL-6755-A

REFERENCE SYMBOL	MOTOROLA PART NO.	DESCRIPTION
C1, 2	8-8205G11	capacitor, fixed: uF, unless otherwise stated
C3	21-83598E21	.22 ± 10%; 50 V
C4	8-8205G41	.01 ± 50-20%; 200 V
C5	23-84538Q02	.39 ± 10%; 50 V
C6	23-84538Q06	4.7 ± 20%; 20 V
C7	21-83598E21	.01 ± 80-20%; 200 V
C8, 9, 10	21-83598E10	.05 ± 20%; 20 V
C11	23-83210A24	1000 uF ± 150-10%; 20 V
C12	23-83201A31	15 ± 20%; 20 V
C13	23-84538Q01	1.0 ± 20%; 35 V
CR1	48-82525G13	diode: (see note)
CR2	48-82525E12	silicon
CR3, 4, 5	48-83854H01	silicon
DS1, 2	65-64991B03	lamp, incandescent .08A, 14 V
J1		connector, receptacle: p/o 28-conductor cable
L1	24-82190C15	coil, #1 1.2 uH
P1		connector, plug: p/o 28-conductor cable
Q1	48-86964E	transistor: (see note)
Q2	48-86965E	NPN; type M9642
Q3	48-86964E	NPN; type M9642
Q4	48-86965E	NPN; type M9638
Q5	48-86943E	PNP; type M9432
Q6	48-86964E	NPN; type M9638
Q7	48-86967D	PNP; type M9607
Q8	48-86964E	NPN; type M9648
R1	18-82520M01	resistor, fixed: ± 5%; 1/4 W unless otherwise stated: var. 25k, incl. ref. item S1
R2	6-124C77	15k ± 10%
R3	6-124C73	10k ± 10%
R4	6-124D10	330k ± 5%
R5	6-124A86	20k
R6	6-124A55	1.8k
R7	18-82519M02	var. 5k
R8	18-82519M03	var. 5k
R9	6-124C33	220 ± 10%
R10	6-124A29	150
R11	6-124A53	1.5k
R12	6-124A55	1.5k
R13	6-124A93	68k
R14	6-124A57	5.6k
R15	6-124A73	10k
R16	6-124A33	220 ± 10%
R17	6-124A42	1k
R18	6-124A35	270
R19	6-124A13	33
R20	6-124B55	2.7
R21	6-124A25	100
R22	6-125C15	36k 1/2 W; 10%
R23	6-124C65	4.7k ± 10%
R24	6-125C21	68 ± 10%; 1/2 W
R25	6-125A25	100 ± 5%; 1/2 W
R26	6-124CA1	470 ± 10%
R27	6-124C81	20k ± 10%
S1		switch: p/o ref. item R1
S2, 3	40-84293D06	2 slide, push-push
S4	40-83542M01	rotary, 10-position

notes:
 1. For optimum performance, diodes, transistors, and integrated circuits must be ordered by Motorola part numbers.
 2. For "C" Board parts not listed in the above parts list, refer to the Mechanical Parts List.

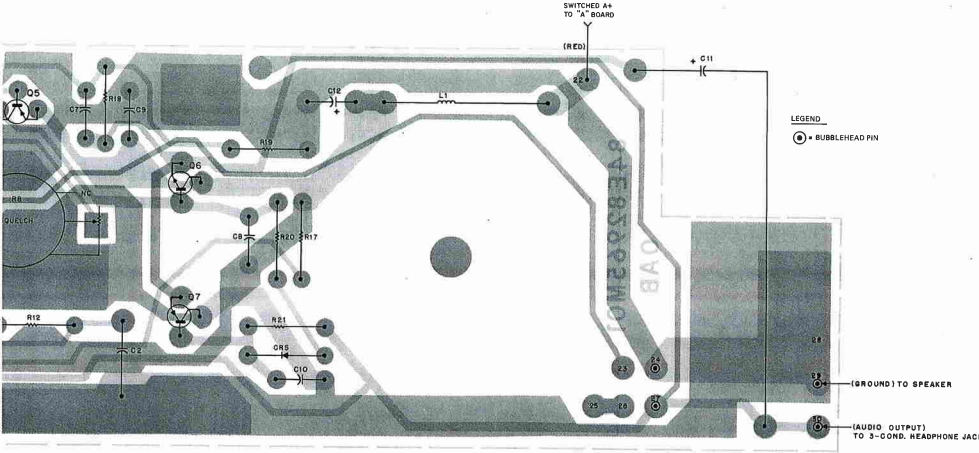

SOLDER SIDE ● 8D-EPS-2914-G
 COMPONENT SIDE ● 8D-EPS-2916-G
 OVERLAY OL-EPS-2916-G

"C" BOARD
MODEL TRN4036A

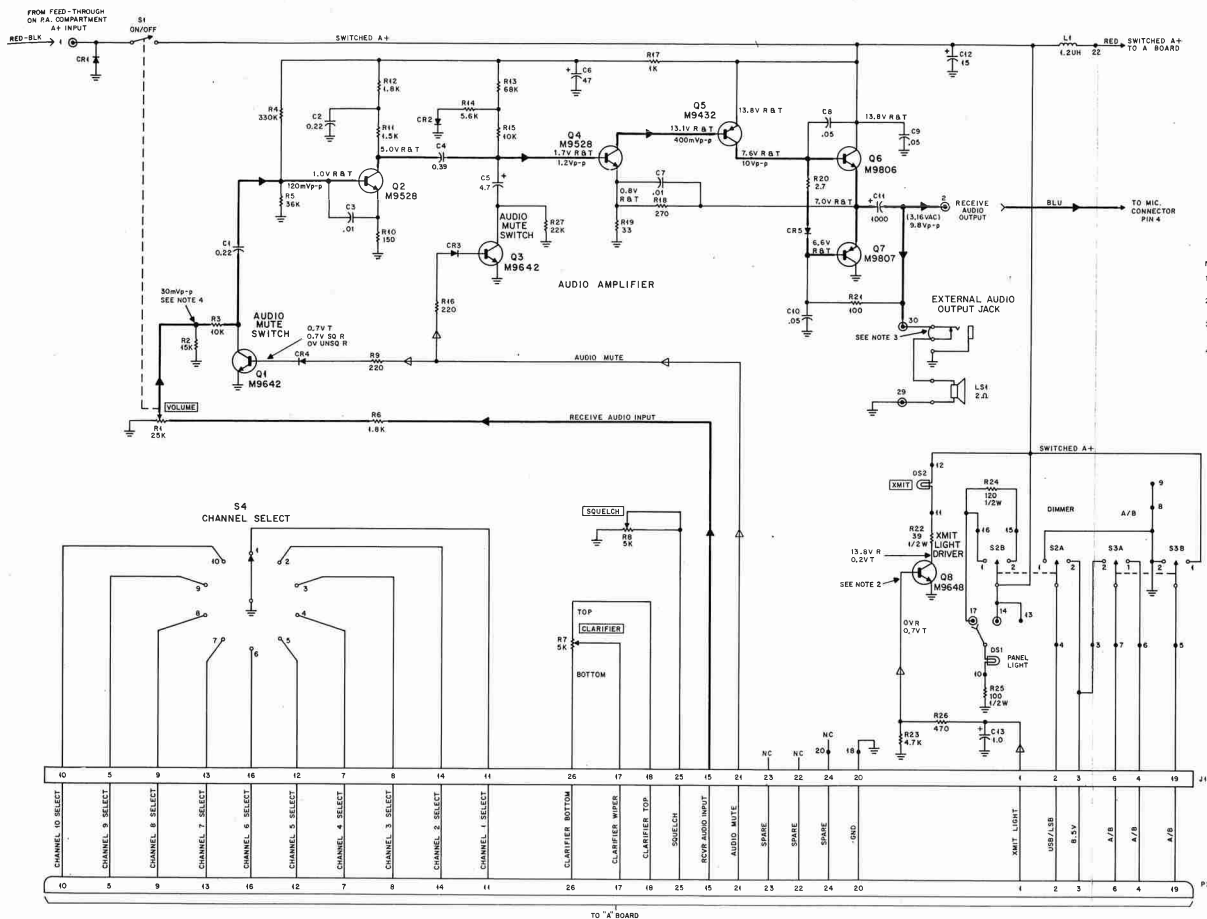

- NOTES:
1. UNLESS OTHERWISE STATED, ALL RESISTOR VALUES ARE IN OHMS, CAPACITOR VALUES ARE IN MICROFARADS.
 2. XMIT VOLTAGES ARE FOR FULL (100 W) RF POWER OUTPUT OF RADIO.
 3. JUMPER CONNECTED WHEN EXTERNAL AUDIO AND SPEAKER AUDIO ARE DESIRED.
 4. DESIGNATED P-P VALUES THROUGHOUT ARE INITIALLY SET BY ADJUSTING AUDIO INPUT DRIVE VOLUME CONTROLS FOR 30 MV P-P AT SPECIFIED NODE R1 R2-R3.

LEGEND:
 ○ DENOTES BUBBLEHEAD PIN CONNECTION
 ● DENOTES PAD

DEPS-29133-A

Motorola No. DEPS-29133-A
12/15/80-PH1

"C" HARMONIC FILTER BOARD

HARMONIC FILTER BOARD

MODEL TFA6061B

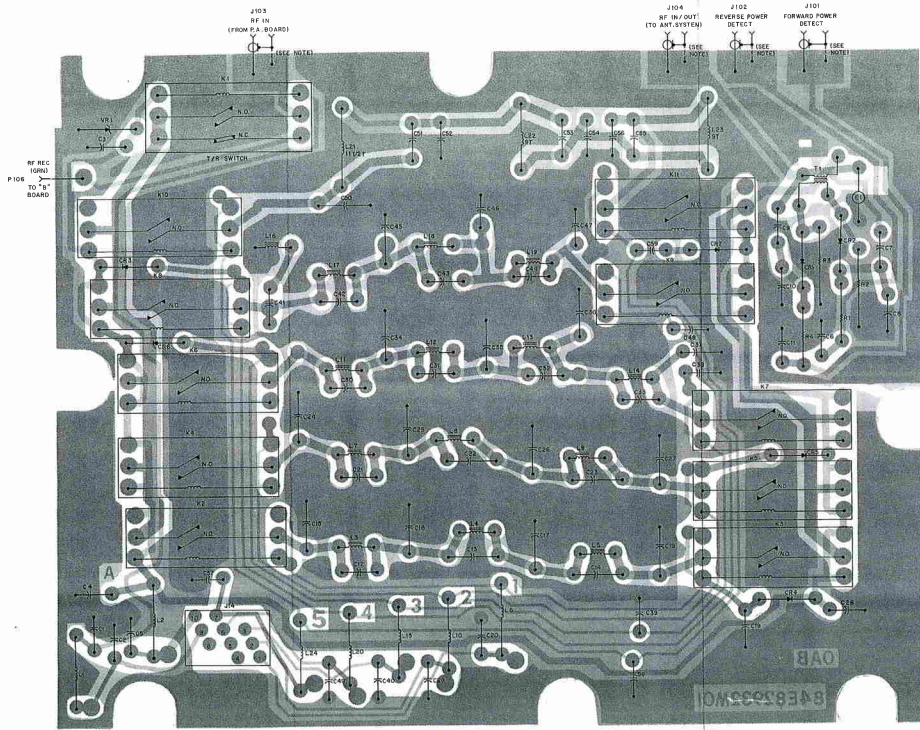

SHOWN FROM COMPONENT SIDE

NOTE:
GROUND CONNECTIONS FOR
J101-J104 ARE MADE TO THE
REVERSE SIDE OF THE BOARD.

COMPONENT SIDE
SOLDER SIDE

80-EPFS 2909B-D
80-EPFS 29099-D
OL-EPFS 2910D-A

Motorola No. PEPS-29299-A
12/15/80-PHI

parts list

TFA6061B Harmonic Filter (Land) PL 6752-A

REFERENCE SYMBOL	MOTOROLA PART NO.	DESCRIPTION
C1 thru 5	21-82272C10	capacitor, fixed; pf ± 2%; 500 V
C6	21-82187B20	.001 uF ± 20%; 25 V
C7	21-82133G22	.8 ± 5 pF
C8	21-84404B81	300 ± 3%; 300 V
C9	21-82133G22	.8 ± 5 pF
C10	21-84404B81	300 ± 3%; 300 V
C11	21-82187B20	.001 uF ± 10%; 100 V
C12	21-84857K42	140
C13	21-84857K44	800
C14	21-84857K51	570
C15	21-84857K58	1100
C16	21-84857K57	1900
C17	21-84857K36	160
C18	21-84857K53	700
C19, 20	21-82372C10	.05 uF ± 20%; 25 V
C21	21-82372C10	.05 uF ± 20%; 25 V
C22	21-84857K51	570
C23	21-84857K41	360
C24	21-84857K52	730
C25	21-84857K55	1250
C26	21-84857K46	1100
C27	21-84857K51	570
C28, 29	21-82372C10	.05 uF ± 20%; 25 V
C30	21-84857K41	75
C31	21-84857K44	180
C32	21-84857K46	310
C33	21-82372C10	.05 uF ± 20%; 25 V
C34	21-84857K46	470
C35, 36	21-84857K49	450
C37	21-84857K43	160
C38, 39, 40	21-82372C10	.05 uF ± 20%; 25 V
C41	21-82372C10	.05 ± 20%; 25 V
C42	21-84857K39	50
C43	21-84857K45	240
C44	21-84857K41	75
C45	21-84857K48	400
C46	21-84857K46	390 ± 3%
C47	21-84857K44	190
C48, 49	21-82372C10	.05 ± 20%; 25 V
C50	21-82372C10	.05 ± 20%; 25 V
C51	21-83406D82	38
C52	21-84857K45	240
C53	21-82372C10	140
C54	21-84857K44	190
C55	21-82372C10	100 ± 1%
C56	21-84857K40	65
C57, 58, 59	21-82372C10	.05 ± 20%; 25 V
CR1, 2	48-82178A08	diode; (see note)
CR3 thru 7	48-82065H01	germanium silicon
E1	80-83209H04	spark gap; 350 V ± 15%
J13		connector, receptacle; pin 10-conductor cable
K1	80-83290M02	relay, reed; form C; 15.6 V
K2 thru 11	80-83290M01	1-form A; normally open
L1, 2	24-82548D41	coil; LF
L3	24-83369M02	2.7 uH, coded RED/VIO
L4	24-83369M04	1.8 uH, coded BRN/GRY
L5	24-83369M03	2.0 uH, coded RED/BLK
L6	24-82548D41	100 uH
L7	24-83369M04	1.8 uH, coded BRN/GRY
L8	24-83369M07	1.2 uH, coded BRN/RED
L9	24-83369M05	1.4 uH, coded BRN/YEL
L10	24-82548D41	100 uH, coded
L11	24-83369M03	1.9 uH, coded BRN/BLK
L12	24-83369M06	1.3 uH, coded BRN/ORG
L13	24-83369M08	1.0 uH, coded BRN/BLK
L14	24-83369M07	1.2 uH, coded BRN/RED
L15	24-82548D41	100 uH, coded
L16	24-83369M11	.75 uH, coded VIO/GRN
L17	24-83369M10	0.8 uH, coded BLK/GRY
L18	24-83369M12	.54 uH, coded GRN/YEL
L19	24-83369M11	.75, coded VIO/GRN
L20	24-82548D41	100 uH
L21	24-84388M12	11.10-T
L22, L23	24-84388M11	9
L24	24-82548D41	100 uH
P13		connector, plug; pin 10-conductor cable
R1	6-124A51	resistor, fixed; 1.2k ± 5%; 1/4 W
R2, 3	6-125A11	27 ± 5%; 1/2 W
R4	6-124A51	1.2k ± 5%; 1/4 W
T1	25-83727K01	transformer; toroid, 25-turns; RED
VR1	48-82296C42	voltage regulator; (see note) Zener, 25 V

HARMONIC FILTER BOARD

MODEL TFA6061B

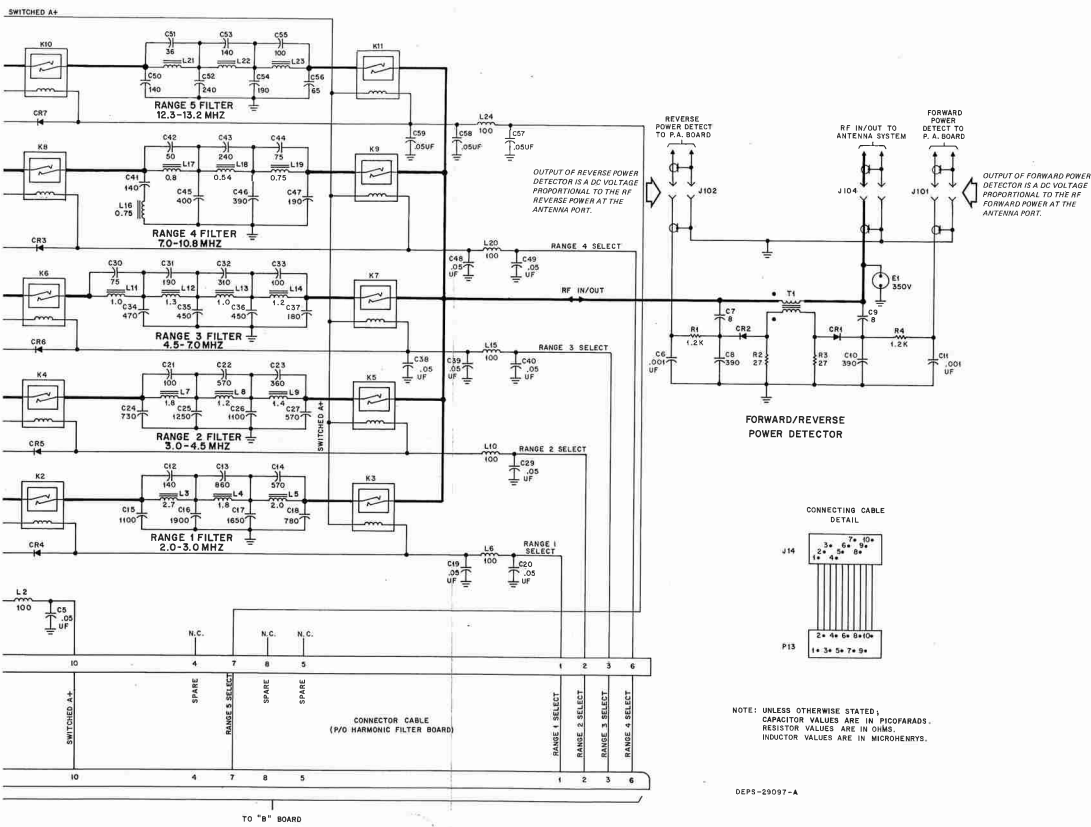

HARMONIC FILTER BOARD

Motorola No. DEPS-29097-A
12/15/80-PH1

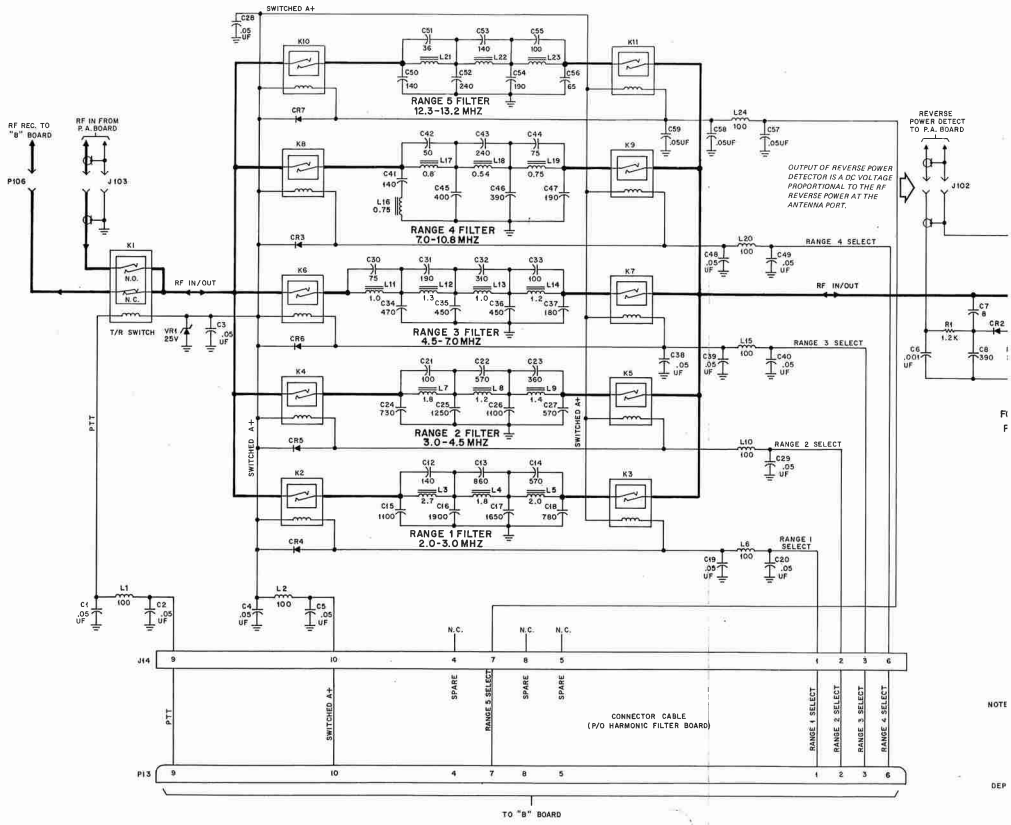

NOTE
DEF

POWER AMPLIFIER BOARD
MODEL TRN4038A

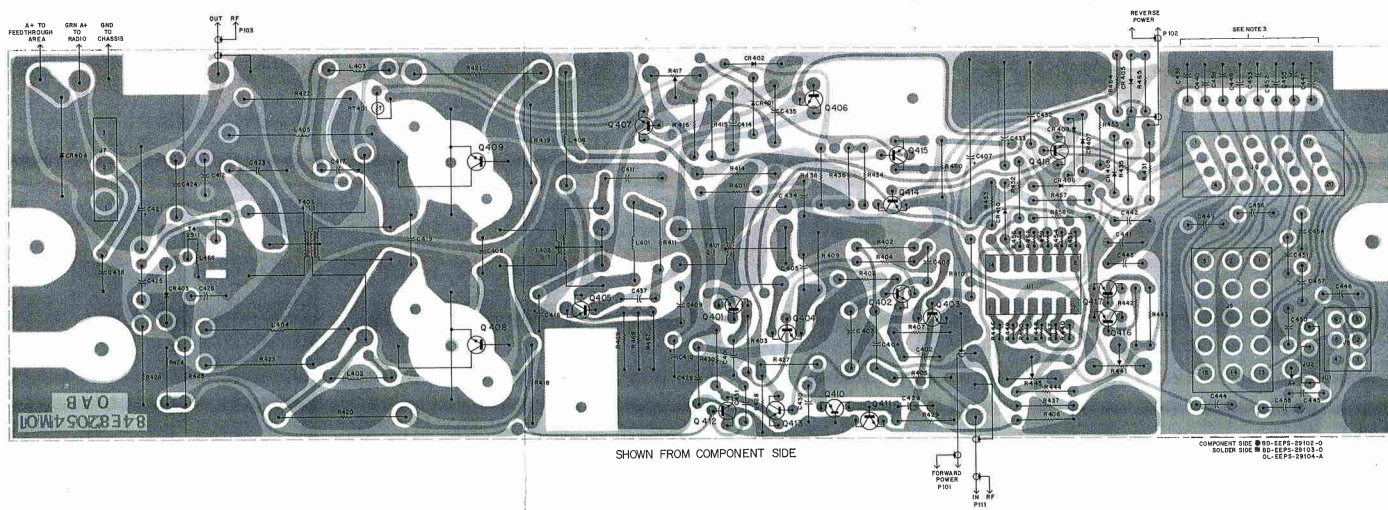

Motorola No. PEPS-29305-A
 12/13/80-PH1

parts list

TRN4038A Power Amplifier Board PL-6756-A

REFERENCE SYMBOL	MOTOROLA PART NO.	DESCRIPTION
C401	21-83596E21	capacitor, fixed, uF:
C402	21-84484B19	01 ± 80-20%, 200 V
C403, 404	8-82955C08	470 pF ± 5%, 300 V
C405	21-83372C10	033 ± 10%, 50 V
C406	21-83596E21	05 ± 20%, 25 V
C407	23-8501A31	01 ± 80-20%, 200 V
C408	21-83372C10	15 ± 100-10%, 25 V
C409	21-83596E22	.001 ± 10%, 200 V
C410	21-83372C10	.05 ± 20%, 20 V
C411	8-83813H01	0688 ± 10%, 100 V
C412	21-83372C10	.05 ± 20%, 25 V
C414	21-83372C05	0.2 ± 80-20%, 25 V
C415	21-83372C10	.05 ± 20%, 25 V
C418	23-84538G04	15 ± 20%, 20 V
C417	23-83372C10	.05 ± 20%, 25 V
C419	21-84484B34	2000 pF ± 5%, 500 V
C421	23-84585C01	15 ± 20%, 25 V
C423	21-83372C05	0.2 ± 80-20%, 25 V
C424	8-82955C17	.047 ± 10%, 100 V
C425	21-85133Q22	8 pF ± 50%, 500 V
C426	21-84484B32	110 pF ± 5%, 500 V
C428	21-83372C09	0.1 ± 80-20%, 25 V
C430, 430, 431	21-83596E21	01 ± 80-20%, 200 V
C432	23-83214C04	1.0 ± 20%, 15 V
C433	23-83214C10	47 ± 20%, 15 V
C434, 438	21-83372C10	.05 ± 20%, 25 V
C435	21-83372C09	0.1 ± 80-20%, 25 V
C437	21-83372C10	.05 ± 20%, 25 V
C438 thru 443	21-83596E21	01 ± 80-20%, 200 V
C444 thru 459	21-83372C10	.05 ± 20%, 25 V
CR401, 402	48-82466H13	diode (see note)
CR403	48-83654H01	silicon
CR404	48-83295N13	silicon
CR405 thru 410	48-83654H01	silicon
J6	30-83265M01	connector, receptacle
J7	38-83510M01	p/c 20-conductor, flat cable
J8	9-83303M01	male, 8-contact
J9	9-83309M01	female, 8-contact
J9	9-83309M01	female, 15-contact
L401	24-82835G13	coil, rf
L402, 403	24-83981B01	82 uH
L404, 405	24-82498P	3 turns
L406	24-82498P	2.15 uH
L406	24-82498P	1.8 uH
P3	30-83265M01	connector, plug
		p/c 20-conductor flat cable
Q401	48-869643	transistor (see note)
Q402	48-869642	PNP; type M9643
Q403	48-869642	NPN; type M9642
Q404	48-869646	NPN; type M9648
Q405	48-869657	NPN; type M9657
Q407	48-869832	NPN; type M9832
Q410	48-869643	PNP; type M9643
Q411, 412, 413	48-869642	NPN; type M9642
Q415, 416, 417	48-869643	PNP; type M9643
Q418	48-869642	NPN; type M9642
Q419	48-869643	PNP; type M9643
R401	6-124C89	resistor, fixed: ± 5%; 1/4 W; unless otherwise stated
R402	6-124A85	47k, 10%
R403	6-124A47	820
R404	6-124A51	1.2k
R405	6-124A21	68
R406	6-124C65	4.7k, 10
R407	6-124C15	39
R408	6-124A81	22k
R409	6-124A13	33
R410	6-124C49	1k ± 10%
R411	6-124A25	100
R414	6-124A29	150, 1/2 W
R415	6-124A53	1.5k
R416	6-124A11	27
R417	19-83083G15	var, 100
R418, 419	6-125B82	5.1, 1/2 W
R420, 421	6-122C17	47 ± 10%; 2 W
R422, R423	6-128C25	100 ± 10%; 1 W
R424	6-124A53	1.5k
R425	6-124A71	8.2k
R426	6-125A20	82, 1/2 W
R427	6-104C49	1k ± 10%
R428	6-124C81	22k ± 10
R429	6-124C89	47k ± 10%
R430, 431	6-124C65	4.7k ± 10%
R434	6-124A85	4.7k
R435	6-124A85	33k
R436	6-124A61	3.3k
R437	6-124A89	47k
R438	6-124A67	5.6k
R440	6-124C89	47k ± 10%
R441	18-83093G01	var, 100k
R442, 443	6-124C81	22k ± 10%
R444	6-124A61	3.3k
R445	18-83093G01	var, 100k
R446	6-124A81	56k
R447 thru 451	6-124A97	100k
R452	6-124A55	4.7k
R453	6-124A89	47k
R454	6-124A53	180
R455	6-124A81	22k
R456	6-124A71	8.2k
R457	6-124A81	3.3k
R458	6-124A91	56k
R459	6-124C85	4.7k ± 10%
R460	6-124C57	2.2k ± 10%
R462	6-124A97	100k
R463	6-124C57	2.2k ± 10%
R464	6-124A91	56k
R465	6-124A81	3.3k
R467, 468, 469	6-124B55	2.7 ohm
RT401	6-83000K05	thermistor: 100k ± 5%; @ 25 °C
T401, 402	1-80718D22	transformer:
T403	24-83227M01	assy, 2 turns green
T404	25-83277K01	4 turns, coded blu. torroid, 25 turn; .390" dia.
U1	51-84320A63	integrated circuit: (see note) type MC3301P

REFERENCE SYMBOL	MOTOROLA PART NO.	DESCRIPTION
R441	18-83093G01	var, 100k
R442, 443	6-124C81	22k ± 10%
R444	6-124A61	3.3k
R445	18-83093G01	var, 100k
R446	6-124A81	56k
R447 thru 451	6-124A97	100k
R452	6-124A55	4.7k
R453	6-124A89	47k
R454	6-124A53	180
R455	6-124A81	22k
R456	6-124A71	8.2k
R457	6-124A81	3.3k
R458	6-124A91	56k
R459	6-124C85	4.7k ± 10%
R460	6-124C57	2.2k ± 10%
R462	6-124A97	100k
R463	6-124C57	2.2k ± 10%
R464	6-124A91	56k
R465	6-124A81	3.3k
R467, 468, 469	6-124B55	2.7 ohm
RT401	6-83000K05	thermistor: 100k ± 5%; @ 25 °C
T401, 402	1-80718D22	transformer:
T403	24-83227M01	assy, 2 turns green
T404	25-83277K01	4 turns, coded blu. torroid, 25 turn; .390" dia.
U1	51-84320A63	integrated circuit: (see note) type MC3301P

- notes:
- For optimum performance, diodes, transistors, and integrated circuits must be ordered by Motorola part numbers.
 - For power amplifier parts not listed in the above parts list, refer to the Mechanical Parts List.
 - Capacitors C439, C440, C447, C448, C452, C453, and C456 to be dressed toward the left side as viewed.

parts list

TRN4038A PA Heatsink Hardware Kit (Land and Marine) PL-6754-A

REFERENCE SYMBOL	MOTOROLA PART NO.	DESCRIPTION
Q405	48-84411L01	transistor (see note 1) NPN; type M1101
Q406	48-869996	NPN; type M9606
Q408, 409	48-84411L35	NPN; type M1135

- notes:
- For optimum performance, diodes, transistors, and integrated circuits must be ordered by Motorola part numbers.
 - For Heatsink Hardware parts not listed in the above parts list refer to the Mechanical Parts List.

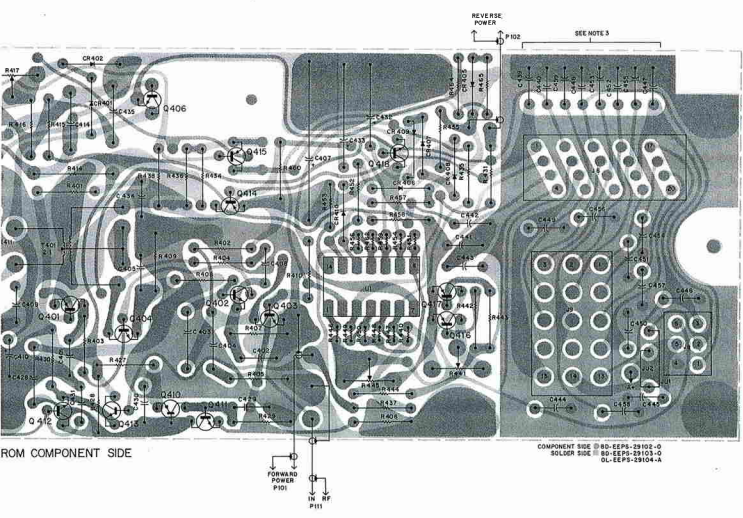

ROM COMPONENT SIDE
COMPONENT SIDE (D-80-EEPS-23102-0)
SOLDER SIDE (D-80-EEPS-23103-0)
DL-EEPS-23104-A

INTERCABLING

parts list

TKN8061A Power Cable (Both Land and Marine) PL-6758-O

REFERENCE SYMBOL	MOTOROLA PART NO.	DESCRIPTION
F1	65-20988	30A, 32 V
F2	65-80099	7.5A, 32 V

note: For Power Cable parts not listed in the above parts list, refer to the Mechanical Parts List behind the Mechanical and Maintenance tab.

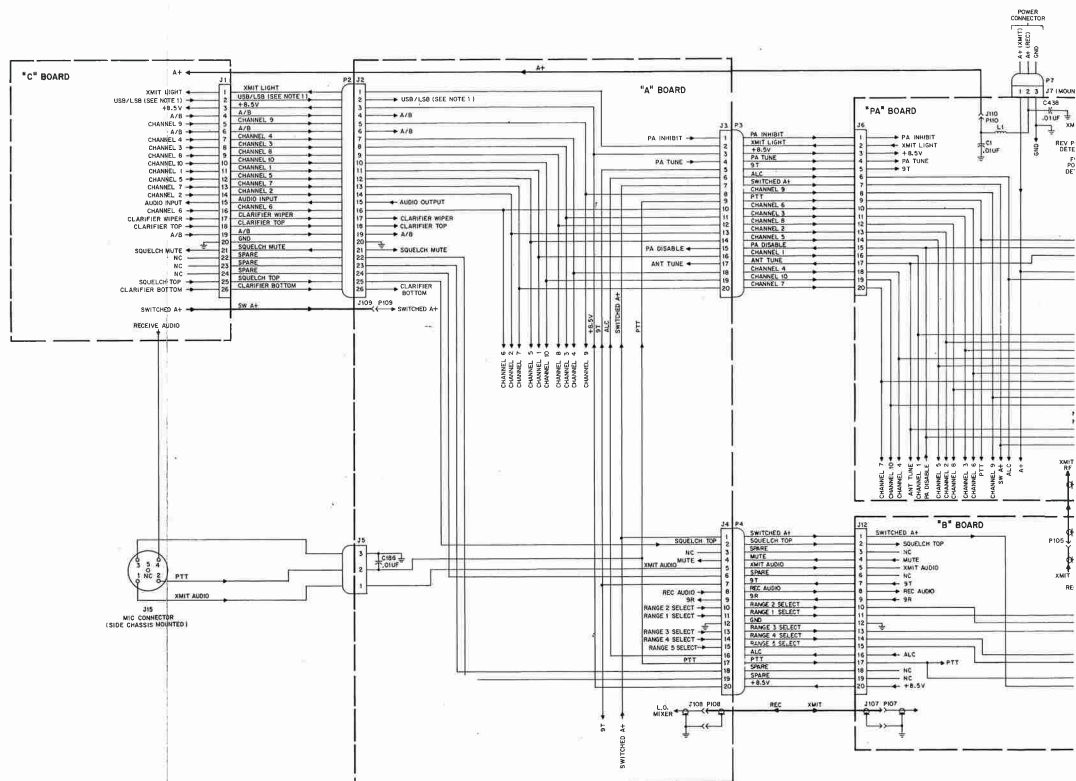

Motorola No. EEPS-29138-A
12/15/80-PHI

4 GND
6 ALC
PTT 1
TUNE 3

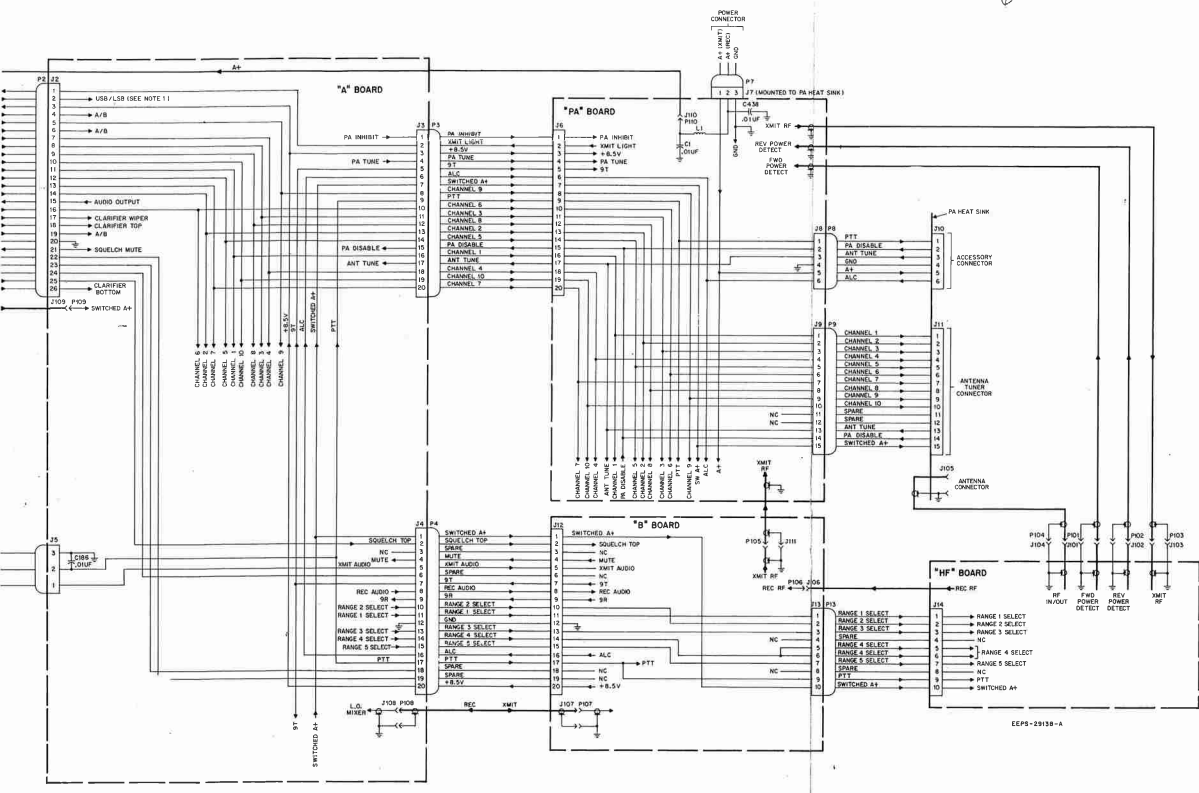

- NOTES:
1. THE USBLSB LINE (PIN 2 OF CONTROL BOARD CONNECTOR) IS USED ONLY ON LAND MOBILE RADIOS; NO CONNECTION ON MARINE RADIOS.
 2. THE FOLLOWING ITEMS ARE PART OF THE CHASSIS INTERCABLEING:

REFERENCE SYMBOL	MOTOROLA PART NO.	DESCRIPTION
C1	21-8421801	0.01UF FREQUENCY CAPACITOR
L1	24-8280801	3 TURN FERRITE BEAD

NON-REFERENCED ITEMS

3--0002100	TERMINAL STRIP
P13 #1470 P1/A	USED WITH C1 AND L1

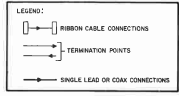

EEP8-28138-A

POWER AMPLIFIER BOARD MODEL TRN4038A

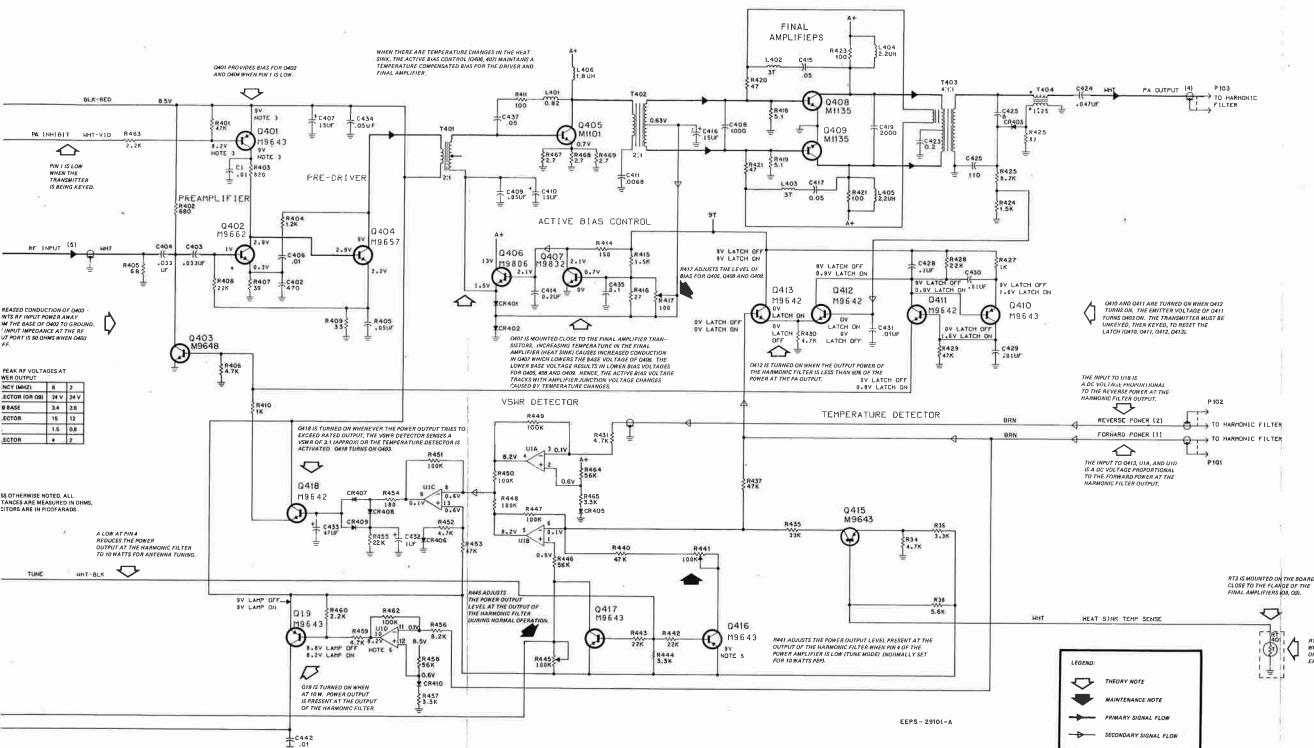

EEPS-22101-A

Motorola No. EEPS-29101-A
12/15/80-PHT

POWER AMPLIFIER BOARD/INTERCABLE

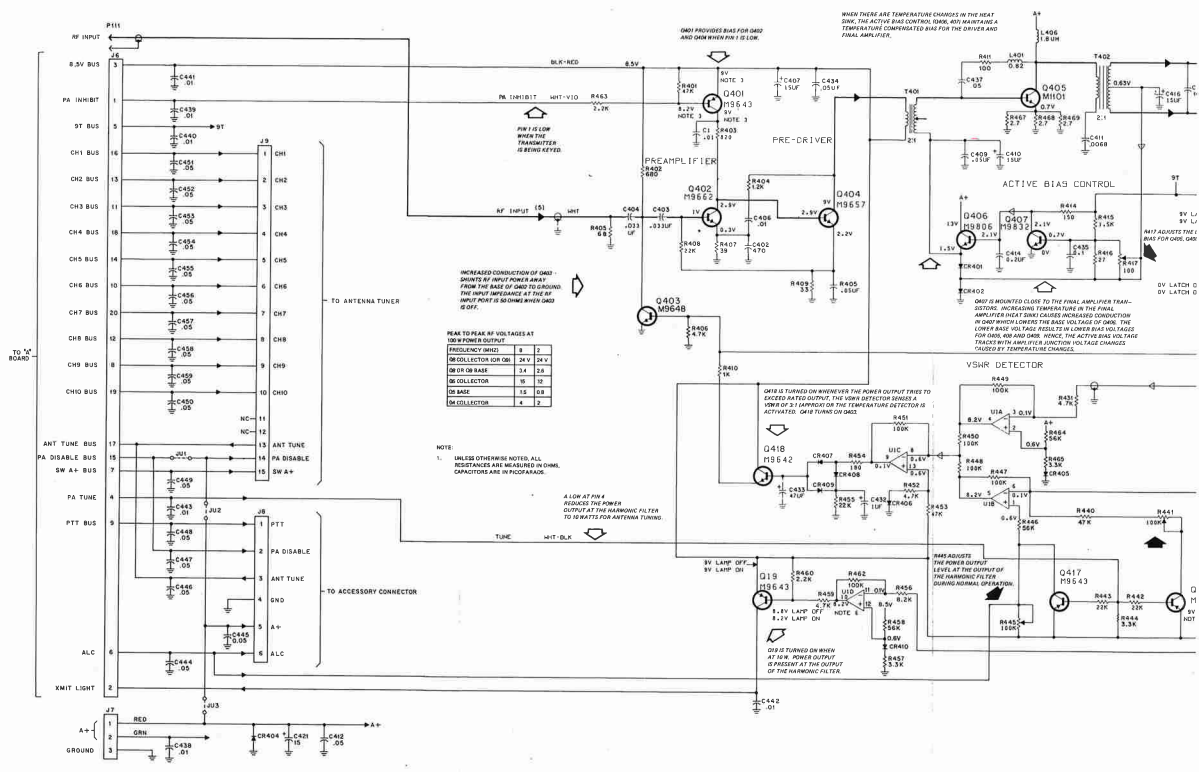



MOTOROLA INC.
Communications
Group

MICROPHONE

MODEL TMN6151A

This microphone is a palm-type unit with a transistorized pre-amplifier. The preamplifier is an integral part of the cartridge. The microphone includes a coiled cord, a five-prong microphone connector, and a built-in push-to-talk switch.

The cartridge incorporated in the microphone provides fidelity inherently greater than that of carbon microphones. Superior voice quality is retained by amplifying the voice signals in the transistorized

preamplifier before these signals become subject to the influence of noise due to stray electrical fields. This results in a signal-to-noise ratio and high output. The preamplifier derives its operating power from the standard microphone voltage supplied by the associated Motorola radio equipment.

This unit is housed in a corrosion proof high impact plastic case that minimizes the effects of severe shock and vibration.

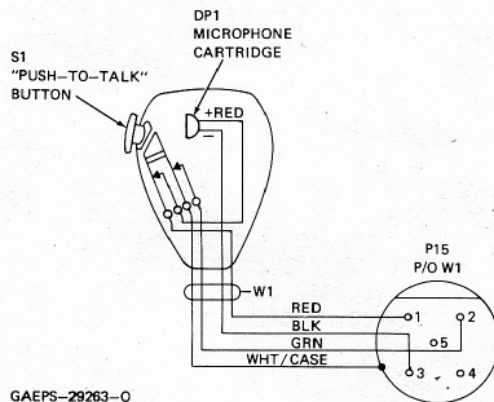

GAEPS-29263-0

parts list

TMN6151A Marine Microphone Kit

PL-6767-0

REFERENCE SYMBOL	MOTOROLA PART NO.	DESCRIPTION
DP1	50-82625L01	cartridge, microphone: transistor amplifier
P15	28-82005M01	connector, plug: 5-contact, male
S1	40-82263G02	switch, PTT: dpst
W1	1-80723D43 29-83277G02 30-852742 42-852707 15-82062M01 43-82061M01	cord, microphone: assembly; includes: ref. items P15, S1 LUG, insulator; 4 used CORD, coiled SPRING, strain relief HOUSING, cord plug COLLAR, connector
non-referenced items		
	3-139096	SCREW, machine: 6-32 x 3/4; 3 used
	3-139999	SCREW, tapping: 6-19 x 3/8"; 3 used
	4-2645	WASHER, lock: #6 ext; 3 used
	4-139097	WASHER, lock: #6 int.; 3 used
	4-139098	WASHER, flat: .156-.250-.015; 3 used
	4-82418B97	WASHER, nylon; 3 used
	33-84052E03	NAMEPLATE
	35-852701	GRILLE, cloth
	38-84559B01	BUTTON, microphone
	42-82702B02	RETAINER, cartridge
	42-84422D01	STRAP
	1-80788B68	HOUSING ASSEMBLY includes: WASHER, back-up WASHER, flat HOUSING, microphone front HOUSING, microphone rear

MICROPHONE