

**WARNING!!!**

**NEVER APPLY POWER TO THIS AMPLIFIER WITH THE COVER REMOVED!  
CONTACT WITH THE VOLTAGES INSIDE THIS AMPLIFIER CAN BE FATAL!**

**PLEASE READ THIS MANUAL BEFORE ATTEMPTING TO OPERATE EQUIPMENT!  
Improper or abusive operation of this amplifier can damage the tubes or other components in  
this amplifier. Damage caused by improper or abusive operation is *not* covered under the  
warranty policy.**

---

## Unpacking Instructions

---

Remove the 3-500Z tube from its shipping carton. Carefully inspect the tube for visible damage. Look for bent or broken pins. Roll the tube over slowly while listening and watching for loose internal materials. Be sure the anode is not off center at the end away from the anode connector. Contact either your Ameritron dealer or Ameritron immediately if any damage exists.

Carefully lift the amplifier from the shipping carton, and place it on a firm, level surface. Inspect the amplifier for shipping damage. Contact either your Ameritron dealer or Ameritron immediately if any damage exists. Remove the cover screws with a #2 Phillips screwdriver. Save the screws to re-secure the cover. Carefully lift the rear of the cover while sliding the cover back. **The AL-80B is shipped with the fuses and fuse caps packed inside the amplifier.** Additional screws will be included in the fuse pack if they are required.

**WARNING:** Never remove the cover while this amplifier is connected to the power mains! Contact with the voltages in this amplifier can be fatal.

The tube must be installed in its socket prior to operation. Observe the pin configuration on the tube and the socket. One of the pins is separated by a large space from the other four pins. Carefully observe the pin alignment to be sure the tube pins are centered on the socket's holes. Firmly press the tube into the socket. **Do NOT twist or force the tube into the socket.**

Install the anode connector on the tube's anode terminal and secure it with the screw provided. Snug the screw enough to secure the anode connector. Do not over-tighten the screw.

Install the fuses and fuse caps on the back of the amplifier. This amplifier uses two 20A fuses for standard 120 Vac operation (models B and BY) or two 10A fuses for 240 Vac operation (model BX only). If you wish to operate the amplifier on a line voltage other than 120 Vac, the jumpers on the power transformer primary windings must be changed. If the primary wiring is changed, the correct fuses must be installed. See the "Transformer Connections" section on page 12 for more information.

**CAUTION** Always use fast-blow fuses rated at 250 Vac or higher. NEVER use standard automotive glass fuses or slow-blow fuses.

The top cover should now be installed with the side ventilation holes positioned on the left (front view). The ventilation holes on the top of the cover should be on the right side of the amplifier (front view). Secure the cover by installing the corner screws first. Install all the screws loosely until every screw is in place. *Tighten the screws after they have all been installed.*

**Note:** *Save all packing materials for future shipping. The packing materials used to ship this amplifier are specially designed to prevent damage. Replacement packing materials may be purchased from Ameritron if original packing materials are unavailable. Ameritron will NOT be responsible for re-shipping damage due to improper packing.*

**Ameritron AL-80B  
1000 watt PEP Linear Amplifier Instruction Manual**

---

Features ..... 1  
AL-80B Technical Specifications ..... 2  
Introduction ..... 3  
    Safety Interlock ..... 3  
Circuit Descriptions..... 4  
    ALC ..... 4  
    Dynamic Bias ..... 4  
Power Supply ..... 5  
    Filament Supply ..... 5  
    Plate (HV) Supply ..... 5  
Meters..... 5  
    Current Meter (plate and grid): ..... 5  
    Multimeter ..... 6  
    Multimeter Functions ..... 6  
    Wattmeter Circuit..... 7  
    Peak Envelope Power vs. Average Power..... 7  
Tube Life ..... 8  
Export Modifications ..... 9  
Technical Assistance ..... 9  
Installation Guidelines And Suggestions ..... 10  
    Location Of The Amplifier..... 10  
    Ventilation..... 10  
    Power Connections..... 10  
    Grounding..... 11  
Transformer Connections ..... 12  
Interconnections ..... 13  
Operating Instructions And Guidelines ..... 13  
    Front Panel Controls..... 13  
        "MULTIMETER" Switch ..... 13  
        "OFF-ON" Switch ..... 13  
        "STBY-OPR" Switch ..... 14  
        "PLATE" Control ..... 14  
        "LOAD" Control ..... 14  
    ALC Metering, Controls, and Adjustments..... 14  
        ALC Metering Functions..... 14  
        ALC Controls ..... 15  
        ALC Adjustments..... 15  
    Rear-panel "ALC LIMIT" control ..... 16  
    ALC Limit Adjustment (rear panel) ..... 17  
Driving Power ..... 17  
Tuning ..... 18  
    Tuning Procedure ..... 18

Additional SSB Notes ..... 22

AM (Amplitude Modulation) Operation ..... 22

FM (Frequency Modulation), RTTY, and Digital Operation..... 22

Audio Distortion..... 22

QSK Operation..... 23

Periodic Maintenance ..... 23

Parts List..... 25

    Power Supply / SWR Board (50-0080-1)..... 25

    Tuned Input Board (50-0080-2) ..... 26

    AL-80B Tuned Input Chart ..... 26

    Meter Board (50-0080-3) ..... 26

    Timer / Overload Board (50-0080-5) ..... 27

    Al-80B Main Chassis Parts List ..... 28

Frequency Coverage..... 29

Amplifier Tuning Log ..... 29

    Notes..... 30

---

## Features

---

- The AL-80B uses a **rugged, inexpensive 3-500Z** tube.
- The 3-500Z requires only a few **seconds of warm-up time**.
- A **dynamic bias circuit** eliminates hundreds of watts of unnecessary heat generation in the power amplifier tube. The result is cooler operation and longer component life.
- A **multi-voltage heavy-duty transformer** with a unique "buck-boost" winding allows adjustment of the primary voltage to 14 different voltages centered on 115 and 230 Vac. This versatile Ameritron feature allows the user to select the optimum primary voltage for maximum performance and life.
- The tuning and loading controls have **vernier 6:1 reduction** drives for smooth tuning. Logging scales allow quick and repeatable control adjustments for rapid band changes.
- The AL-80B has two **illuminated cross-needle panel meters**. The left meter provides a continuous reading of grid and plate currents. The right meter indicates peak RF power output on one scale and Plate Voltage (HV), Reflected power and SWR (REF), ALC detector voltage (ALC), and ALC adjustment level (ALC SET) on the other.
- Filament and plate voltages are maintained using the **"STBY/OPR"** switch. This allows the amplifier to be conveniently bypassed for "barefoot" operation.
- A front panel **"ALC SET" control** allows convenient adjustment of the ALC threshold. The unique ALC circuit samples the grid current and power supply voltage.
- An **"XMT"** LED on the front panel indicates proper keying of the amplifier by the exciter.
- A rear panel **"12 V" auxiliary output jack** provides up to 200 mA at 12 Vdc for accessories such as the ATR-15 Antenna Tuner.
- A **step-start circuit** limits the inrush current to the power supply and tube filament. This circuit extends the life of the amplifier components.

---

## AL-80B Technical Specifications

---

**Input:**

|                                      |                              |
|--------------------------------------|------------------------------|
| Circuit type:                        | Pi-network, slug tuned coils |
| Maximum VSWR at resonance:           | 1.3:1 or less                |
| Minimum 2:1 VSWR bandwidth:          | 20% of center frequency      |
| Maximum drive power permissible:     | 100 watts PEP                |
| Typical drive for full power output: | 85 watts                     |

**Output:**

|                                     |  |
|-------------------------------------|--|
| Circuit type:                       | Pi-L, Pi-network   |
| Typical SSB PEP voice operation:    | 1000+ watts  |
| CW continuous operation:            | 800 watts  |
| 1/2 hour PEP two-tone test:         | 850 watts  |
| 1/2 hour continuous carrier (RTTY): | 500 watts  |
| Frequency Coverage:                 | 1.8 to 21 MHz amateur bands. (Export models include 24.5 and 28 MHz) |
| Third Order IMD:                    | -35 dB or better (at rated output)                                   |

**Efficiency:**

|      |                                    |
|------|------------------------------------|
| CW:  | approximately 65%                  |
| SSB: | approximately 65% (envelope crest) |

**Power Supply:**

|  |                                      |
|--|--------------------------------------|
| Circuit type:                                | Full wave voltage doubler            |
| No load voltage:                             | 3100 V                               |
| Full load voltage:                           | 2700 V                               |
| Full load current:                           | .6 A                                 |
| Regulation:                                  | >13%                                 |
| Transformer:                                 | 26 lb. E-I lamination grain oriented |
| Capacitors:                                  | 26 mFd total, computer grade         |
| Normal line current at rated CW output:      | 12 A at 120 Vac                      |
| Normal line current at 1000 watt PEP output: | 8 A at 120 Vac                       |
| Power line current in standby:               | 1 A at 120 Vac                       |

**Tube:**

|                         |                   |
|-------------------------|-------------------|
| Type:                   | 3-500Z            |
| Continuous dissipation: | 500 watts         |
| Warm-up time:           | 10 seconds        |
| Estimated life:         | 12,000 hours ICAS |

**Metering:**

|                |   |
|----------------|---|
| Multimeter:    | Peak forward power (continuous). The second scale switches between peak reflected power (and SWR), ALC threshold, ALC output voltage, and high voltage. |
| Current meter: | Plate and grid current (simultaneously) on separate scales.   |

**ALC:**

Negative going, 0 to 10 volts, adjustable.

**Relay:**

Requires contact closure or sink of +12 Vdc at 100 mA. Back pulse protected.

**Connectors:**

|         |                                       |
|---------|---------------------------------------|
| RF:     | SO-239                                |
| Line:   | NEMA 5-15P, standard 120 V three wire |
| Others: | RCA Phono                             |

**Physical:**

|             |                                  |
|-------------|----------------------------------|
| Dimensions: | 15-1/2" D x 14-1/2" W x 8-1/2" H |
| Weight:     | 48 lbs.                          |

---

## Introduction

---

The Ameritron AL-80B is an 800 watt CW, 1000 watt PEP output linear amplifier that operates on all Amateur bands from 160 through 15 meters. The AL-80BX and AL-80BY are export models that operate from 160 through 10 meters. Export modification instructions are available with proof of a valid amateur radio license.

The AL-80B uses a single 3-500Z tube in a class AB2 grounded grid circuit. High-quality power supply and RF components combine with an accurate peak-detecting directional coupler, front panel adjustable true ALC circuit, and automatic bias switching to make this the best featured and most reliable single 3-500Z amplifier available. The AL-80B and AL-80BY are factory-wired for 120 Vac, 50/60 Hz line voltage. The AL-80BX is factory wired for 240 Vac. All models are easily converted to other supply voltages between 90 and 250 Vac.

### Safety Interlock

The top cover of the AL-80B operates an interlock switch which completes the primary circuit of the power transformer. The interlock will open and de-energize the transformer primary if the top cover is removed.

|   |
|---|
| <p><b>WARNING</b> High voltage can kill!! Accidental contact with the voltages in this amplifier<br/>: can be lethal!!!</p> |
|---|

*For your personal safety, please observe the following precautions:*

1. **NEVER** defeat the interlock.
2. **NEVER** remove the cover with the amplifier connected to the power line.
3. **ALWAYS** allow several minutes for the capacitors to discharge *after* unplugging the amplifier and *before* removing the cover.
4. **ALWAYS** select the high-voltage (HV) function of the Multimeter to check the high voltage potential. Do **not** remove the cover if voltage is indicated.
5. **ALWAYS** ground the tube anode (top metal conductor) to the chassis before touching anything inside the amplifier.
6. **ALWAYS** be cautious of heat. Many components inside the amplifier operate at high temperatures.
7. **NEVER** make any unauthorized component or circuit modifications to this product. The *only* acceptable source for modifications is Ameritron or a source approved by Ameritron. Unauthorized modifications almost certainly will **increase** the risk of equipment failure or personal injury.

---

## Circuit Descriptions

---

### ALC

The AL-80B is one of the few amplifiers using a "true" automatic level control (ALC) circuit. In this amplifier, the ALC actually samples grid current and power supply loading to determine the ALC voltage. The front panel "ALC SET" knob adjusts the level of grid current where ALC action begins. ALC action begins softly over a range of a few milliamperes to minimize distortion. This soft-touch ALC is an Ameritron exclusive.

The ALC circuit is located on the METER BOARD P/N 50-0080-3 (behind the "MULTIMETER" switch). IC301 (pins 9 and 10) compares the voltage drop (caused by grid current) across R106 in the main power supply board. ALC voltage is derived by comparing the grid shunt voltage to the voltage from the power supply.

The output of IC1 (pin 8) will go negative if the grid shunt voltage exceeds the voltage from divider R311 and R2 (chassis mounted control), or if the supply voltage sags from excessive line voltage drop. Pin 8 is followed by current buffer Q303 that sources the negative ALC voltage to the ALC output jack.

This amplifier includes an ALC Limit control on the rear panel. This control reduces overshoot and eliminates "motor-boating" (a slow rhythmic fluctuation) in the transmitted signal. These problems are caused by excessive transceiver ALC attack time delay. This control sets the maximum voltage level available from the ALC circuit. Adjustment details are given on page 15.

### Dynamic Bias

Conventional bias circuits force high power linear amplifiers to dissipate hundreds of watts during low or no signal periods. This creates needless heat, since virtually no dissipation is required unless the amplifier is being driven with large signal levels.

The AL-80B contains an exclusive bias circuit that reduces the idling (quiescent) current very close to the tube's cut-off region. The power amplifier tube in the AL-80B has a full resting period of very low dissipation between dots and dashes on CW and between words on SSB. The lower idling current reduces component temperature on both CW and SSB. If only a few milliwatts of RF power are applied to the amplifier, the quiescent current will increase. Linearity remains excellent with this circuit because the tube can remain biased for class AB operation without unnecessary standing dissipation.

The dynamic bias circuit is located on the Power Supply Board P/N 50-0080-1. Diodes D101 and D102 rectify a small sample of the RF drive voltage. This voltage is applied to the base of dc switch Q101. If Q101's base is driven with a few microamperes of current from the RF sampling circuit, Q101's collector will pull the base of PNP transistor Q102 low. This turns dc switch Q102 on.

When Q102 is on, zener diode D103 is connected between the collector and base of Q103.

D103 sets the operating bias. This zener applies forward bias to Q103's base whenever the collector voltage of Q103 exceeds the voltage of D103. This forward bias will turn Q103 on harder and will reduce the collector voltage. If the collector voltage is less than the breakdown voltage of D103, Q103 will move towards cut-off and the collector voltage will increase. Q103 functions as a current buffer for zener diode D103.



---

## Power Supply

---

### Filament Supply

The filament circuit of this amplifier satisfies all requirements of the tube manufacturer related to tube performance and life. The filament voltage and inrush current are controlled by the power transformer's internal resistance and impedance, filament choke resistance, filament wiring resistance, and the step-start circuit. NEVER replace any circuit components or wiring with substitute parts. This precaution will insure maximum life for the tube.

### Plate (HV) Supply

The plate supply uses a full wave doubler circuit with 200 amp surge rated diodes and a heavy duty 26 pound grain oriented transformer. Filtering is accomplished by a bank of high quality computer grade capacitors totaling 26 mFd. Large 50k ohm, 7 watt bleeders are used for safety and superior voltage equalization. The transformer allows user selection of fourteen different line voltages (see the "Transformer Connections" section on page 12 for details).

Power is supplied through "OFF-ON" switch S2. A 10 ohm resistor (R27) limits the line current during the filter capacitor charge time to lower component stress. When the filter capacitor charging current decreases sufficiently, RLY102 shorts the 10 ohm resistor. This applies full power line voltage to the transformer. The 10 ohm resistor is protected from high-voltage supply shorts by a 2A slow-blow fuse (F101) during start-up. If F101 or the 10 ohm resistor (R27) fails the amplifier will not start. If F101 fails from a momentary HV to ground fault, meter protection diode D117 may also fail. See the "Metering Functions" section that follows for more information.

---

## Meters

---

### Current Meter (plate and grid):

The plate and grid current meter is located on the far left side of the front panel. This meter indicates the plate current ( $I_p$ ) on the right-hand meter scale. This scale has a small picket every 25 mA, a large picket every 75 mA, and indicates 750 mA at full deflection.

The left-hand meter scale indicates the grid current ( $I_g$ ). The small pickets on this "I<sub>g</sub>" scale appear every 10 mA and the larger pickets appear every 50 mA. The full scale "I<sub>g</sub>" reading is 250 mA.

The plate and grid meters in this amplifier normally indicate maximum grid current and maximum RF output at or near the same "PLATE" tuning setting. Maximum grid current and minimum plate current also generally occur at the same "PLATE" tuning setting.

**NOTE: If the grid and plate meters always track (move together in exact step) as the tuning controls are adjusted and if they show the same approximate amount of pointer movement, diode D117 on the power supply board could be shorted.**

D117 protects the overload circuit (if used) and the meters. This diode is located near the electrolytic capacitors on outside edge of the main circuit board. D117 will usually short if there is a large high-voltage-to-chassis current fault. The grid and plate current meters will not read correctly if this diode fails. If D117 is shorted the overload circuit (if used) may repeatedly trip and the grid current may appear excessively high before full power is reached.

## Multimeter

The multimeter is the meter on the right. It continuously reads the forward *peak envelope power* on its left-hand scale (FWD). This scale is calibrated in 100 watt steps up to 2 kW.

The right-hand scale of this meter provides four metering functions that are selected by the "MULTIMETER" switch. These functions include the measurement of high voltage (HV), reflected power and SWR (REF), ALC voltage output (ALC), and relative ALC threshold (ALC SET). The MULTIMETER FUNCTIONS section that follows describes these functions in more detail.

## Multimeter Functions

**HV:** The multimeter indicates the dc plate voltage applied to the PA tube when the MULTIMETER switch is placed in the HV position. The correct scale to use is the ALC/ HV scale. This scale has a picket every 100 volts. Two zeros must be mentally added behind the numbers indicated on the meter scale (i.e. multiply by 100), so that "25"=2500 volts and "20"=2000 volts. Do not operate the amplifier if the high voltage is over 3200 volts with the amplifier on standby. See the "Transformer Connections" section on page 12 for information on correcting excessive high voltage.

**REF:** The multimeter measures the antenna (or load) peak envelope reflected power and the SWR when the MULTIMETER switch is placed in the REF position. The full scale reflected power reading is 500 watts. This scale is marked every 10 watts below 100 watts, and every 100 watts from 100 to 500 watts.

|  |
|--|
| <p><b>Note:</b> The SWR of the load is measured when the "MULTIMETER" is in the REF position by observing the different red SWR curves. The forward and reflected power meter pointers will cross each other on, or near, the correct SWR curve.</p> |
|--|

**ALC:** The multimeter measures the output voltage of the ALC detector when in the ALC position. The full scale ALC reading is 35 volts and is read directly from the ALC/ HV scale. The meter should flick upwards occasionally during normal ALC action. See ALC Circuit operation on page 15 for more information.

**ALC SET:** The multimeter measures the *approximate* grid current that will produce ALC activity when the meter switch is in the ALC SET position. One zero must be added to the reading on the ALC/ HV scale for this function. For example, ALC action will begin at approximately 150 mA of grid current (typically between 120 mA and 180 mA) when the "ALC SET" control is adjusted until the meter reads "15."

## **Wattmeter Circuit**

The AL-80B wattmeter circuit uses an accurate directional coupler followed by a true peak detector circuit. This circuit will accurately determine the true peak envelope power (PEP) of normal voice waveforms. If the load SWR is high, the true power reading will be obtained by subtracting the reflected power from the forward power.

## **Peak Envelope Power vs. Average Power**

Peak envelope power (PEP) is often misunderstood by amateurs. PEP *is not* associated with the sine wave or root-mean-square (RMS) power, and PEP has no fixed ratio to average power on any mode except FM, FSK or CW. It is impossible to use a formula or "rule of thumb" approximation to convert between average and peak voice waveform powers.

PEP is the power at the crest (highest point) of the RF envelope waveform. On SSB, the average power can vary from a few percent of the PEP to over half of the PEP. Generally, the PEP on SSB is two to five times greater than the average power. A 50 watt average power SSB signal could have peak envelope powers that are lower than 100 watts or that exceed 250 watts.

On CW and other constant amplitude modes (such as FM or RTTY), the PEP is *always equal* to the average power. On CW, FM or RTTY 1000 watts of average power produces exactly 1000 watts of PEP.

---

## Tube Life

---

The 3-500Z is a reasonably rugged tube. The primary concern in this tube are element failures from excessive temperatures. Element temperature is a function of the duration and the amount of power dissipated. The elements in the 3-500Z have very good immunity to short term overload failures.

The anode in the 3-500Z can tolerate large dissipation overloads for short periods of time due to the thermal mass of the anode. Anode color is a good indication of correct tube operation. The anode in the 3-500Z is designed to operate at very high temperatures. These temperatures normally produce a dull to bright red anode color. This is a normal operating condition.

The anode is coated with a "getter" material that de-gasses the tube. This material is activated by the high anode temperatures. The likelihood of a long term gas failure is reduced by operating the 3-500Z with a slight amount of anode color.

Care must be taken to avoid exceeding the temperature ratings of the tube's glass-to-metal seals. The life of the tubes in this amplifier may be prolonged if tuning periods are kept short and a brief "cool-down" periods are provided between tuning periods. Try to allow a one or two minute non-transmitting "cool-down" period after lengthy CW or RTTY transmissions before shutting off the ac power switch.

Incorrect operation is most likely to damage the tube's control grid or anode. Applying full drive power for several seconds with excessively "light" loading can cause control grid damage. Several seconds of high drive power operation with improper tuning or excessively "heavy" loading can melt or damage the anode. These conditions can be avoided by following the tuning procedures in this manual.

In the AL-80B, a grid current of 250 mA (at 100 watts of drive) produces the rated grid dissipation of 20 watts. For maximum tube life, the grid current and drive power should always be kept below these values.

### **WARNING:**

**NEVER drive this amplifier with more than 100 watts of short term average envelope power. NEVER allow the grid current to exceed 250 mA under any operating condition.**

Maximum power output normally will occur with approximately 175 mA of grid current on CW, or approximately 45 mA of maximum grid current (175 mA instantaneous peak) on SSB (two-tone test). The grid dissipation with 175 mA of grid current and 70 watts of drive is approximately ten watts.

If you wish to add control grid protection to the AL-80B, always remember fuses and resistors are too slow and unpredictable to adequately protect tubes. While grid protection is generally not required with tubes like the 3-500Z, Ameritron does offer an optional fast-acting electronic circuit that will rapidly disable the amplifier if excessive grid dissipation occurs. This circuit also reduces or eliminates the chance of tank component damage from incorrect loading or a load failure. The part number of this add on board is 50-01172-1.

---

## AL-80B Instruction Manual

The continuous commercial plate current rating of the 3-500Z is 400 mA. For maximum tube life, plate current should be maintained below 400 mA on CW and other "steady" carrier modes. Brief periods of plate current exceeding 400 mA will not cause loss of emission or shorten the life of the tube in this amplifier.

The application of filament voltage causes thermal stresses from rapid and uneven temperature changes. Needless cycling of the filament may cause premature failure or unnecessary stress in the tube's filament.

An accumulation of gas (or stray debris) in the tube can cause arcs between the anode and the other elements of the tube. The resulting "gas arc" will generally manifest itself as a loud "pop" when the amplifier is first turned on. A "gas arc" will often damage diode D117 on the negative rail of the filter capacitor bank and open the fuses in the amplifier. If this problem occurs frequently, the tube should be tested or replaced. The use of low quality tubes, tubes that have been stored for extended periods, or abused tubes increase likelihood of a "gas arc". Ameritron recommends using only current code date Eimac 3-500Z tubes.

---

## Export Modifications

A simple modification will allow operation on frequencies above 15 meters. Instructions for this modification are available by sending a written request for "Export Modification Instructions" along with a copy of a valid amateur license. There is no charge for this information. Export models are shipped with this modification installed and have an "X" or "Y" following the serial number. Standard frequency ranges are indicated in the chart on page 29.

---

## Technical Assistance

Technical assistance is available during normal central standard time business hours on weekdays. Customer service is more effective when our engineers are provided the following information:

- 1. Model and serial number**
- 2. Date of purchase and dealer**
- 3. An accurate description of the problem**

Meter readings at all stages of the tuning procedure are very important along with a complete description of the other equipment used with our product.

Written assistance is also available. Due to time delays in processing mail, please allow at least three weeks for a written reply. For service or written correspondence, use the following address:

**AMERITRON  
116 Willow Road  
Starkville, MS 39759  
Telephone (662) 323-8211  
FAX (662) 323-6551**

|  |
|--|
| <p><b>NOTE:</b> Service history has clearly shown that most problems are operating or installation errors, rather than equipment failures. Most problems can be resolved over the telephone. Please contact our staff <i>before</i> shipping parts or equipment to us.</p> |
|--|

The packing materials used to ship this amplifier were specially designed to prevent shipping damage. The original packing materials should be used to ship this amplifier. Replacement packing materials may be purchased from Ameritron if original packing materials are unavailable or damaged.

**CAUTION: Never ship this amplifier with the tube installed. Ameritron will *not* be responsible for shipping damage caused by improper packing.**

---

## Installation Guidelines And Suggestions

---

### Location Of The Amplifier

Do not install the amplifier in excessively warm locations or near heating vents or radiators. Be sure air can circulate freely around and through the amplifier cabinet. Provide an unobstructed cold air inlet for the amplifier. **DO NOT** place any books, magazines or equipment that will impede the free flow of air on or near the cabinet ventilation holes.

### Ventilation

The AL-80B ventilation system has been designed and tested to maintain tube seal temperatures safely below the tube manufacturer's rating at 500 watts of continuous carrier output, or 800 watts of continuous two-tone or CW power output when the amplifier is properly tuned. The fan in the AL-80B is a permanently lubricated type that requires no maintenance in normal operation. To insure adequate cooling in your installation, please observe the following:

1. Do not block or unduly restrict the ventilation holes in the cover. Be sure that the amplifier is located in an area so the ventilation holes have open air circulation. It is particularly important to avoid restricting the air inlet.
2. The exhaust airflow is over 30 CFM. Do not "assist" the exhaust airflow with cabinet mounted fans.
3. The most efficient way to improve airflow is to pressurize the air *inlet* area. Be sure that any fan used to assist the inlet airflow has *at least* a 60 CFM rating.
4. The exhaust air will become quite warm at high power levels. Do not place any heat sensitive objects in the exhaust air stream.

### Power Connections

The AL-80B is supplied with a NEMA 5-15P plug for 120 Vac operation. Full duty cycle operation with ac supply voltages below 100 volts is not recommended. The "Transformer Connections" section on page 12 shows the correct wiring for various supply voltages.

This amplifier has a current demand of 14 amperes at 120 Vac with 1000 watts of RF carrier output. The average power line current during voice peaks on SSB will be approximately 9 amperes at 1000 watts PEP output. The average current demand on CW will be less than 12 amperes. Most normal residential power lines and house-wiring will easily meet this current requirement.

---

## AL-80B Instruction Manual

If the power mains have excessive resistance, the high voltage may sag to less than 2700 volts under load. Voltage sag will not hurt the amplifier if the fully loaded high voltage remains above 2500 volts.

**CAUTION: Never allow the high voltage to exceed 3200 volts under any condition.**

For 120 Vac operation, the wiring between the fuse box and the amplifier ac outlet must be number 14 gauge (or larger) in order to supply the current required (12 A) without a significant drop in the line voltage. The 120 volt outlet should be fused for 20 amperes.

### Grounding

Connect a good RF and dc ground to the ground post on the rear panel of the amplifier. Use the heaviest and shortest connection possible. The best materials to use for ground connections are (in order of effectiveness) smooth wide copper flashing, copper tubing, or solid copper wire. *Never use braided or woven conductors unless the lead needs to be flexed.* Braided or woven conductors offer a much higher impedance to lightning and RF than equivalent solid conductors.

Water pipes, metal heating ducts, metal fences and other large metallic masses offer convenient RF grounds. If a water pipe ground is used, inspect all the pipe connections to be sure that no plastic or rubber connections are insulating the pipes. Insulated pipe connections will interrupt the electrical continuity in the water supply system. Install a jumper around any insulated pipe connections you find. Use heavy copper wire or flashing with stainless hose or pipe clamps for the jumpers.

*The following tips will help prevent lightning damage and RF grounding problems:*

1. Avoid using braided or woven conductors, they have very high resistance for RF and lightning. Remember that RF and lightning flows along the surface of conductors, almost no current flows in the center of the conductor. The lowest RF resistance occurs with wide, smooth conductors.
2. Avoid routing a single small gauge conductor along the various pieces of equipment (or to connect multiple ground sources). Instead, use multiple ground leads that connect to a single wide buss at the operating position. Keep all ground leads as short and wide as possible.
3. Buried radials provide much better lightning and RF ground connections than ground rods do, although both are needed for safety.
4. Avoid sharp bends in ground leads. When changing the direction of a ground lead use a gradual radius turn.
5. Avoid second story operation. A good ground is much easier to obtain on the first floor or in the basement of a structure.
6. Air-core choke baluns should be used on all coaxial feedlines. The feedlines should be coiled into several 4" to 6" diameter turns *before* they enter the building. Either directly bury the feedlines a few inches deep in the ground for a minimum distance of ten feet or ground the shields to a separate earth ground on the antenna side of the choke.

## Transformer Connections

The power transformer of the AL-80B has fourteen different voltages available on the primary and is rated at full power on frequencies of 50 and 60 Hz. The "JUMPER CONNECTIONS" chart below indicates the proper placement of jumpers for various power line voltages.

The high voltage secondary of the AL-80B has three leads. The normal wiring is indicated on the circuit board silk-screen by the initials R/Y (RED/YELLOW) and R/G (RED/GREEN). For low power operation the R/Y and R/G wire can be reversed. This will reduce the plate voltage of the AL-80B to permit operation at output levels below 400 watts.

**WARNING:** The AL-80B requires different back panel fuses for various line voltages. Use the fuse listed above for maximum protection.

| HIGHEST<br>LINE-V | JUMPER FROM TOP LETTERS<br>TO BOTTOM LETTERS IN COLUMN |   |   |   |   |   | LINE<br>FUSE |
|-------------------|--|---|---|---|---|---|--------------|
|                   | A  | B | C | D | E | F |              |
| 205               |  | C | B |   | 3 | 1 | 12           |
| 215               |  | C | B |   | 3 | 2 | 12           |
| 220               |  | C | B |   | 2 | 1 | 12           |
| 230               |  | C | B |   | F | E | 10           |
| 240 <sup>†</sup>  |  | C | B |   | 1 | 2 | 10           |
| 245               |  | C | B |   | 2 | 3 | 10           |
| 250               |  | C | B |   | 1 | 3 | 8            |
|                   |  |   |   |   |   |   |              |
| 90                | B  | A | D | C | 3 | 1 | 25           |
| 100               | B  | A | D | C | 3 | 2 | 25           |
| 110               | B  | A | D | C | 2 | 1 | 25           |
| 115               | B  | A | D | C | F | E | 20           |
| 125 <sup>†</sup>  | B  | A | D | C | 1 | 2 | 20           |
| 130               | B  | A | D | C | 2 | 3 | 20           |
| 140               | B  | A | D | C | 1 | 3 | 15           |

<sup>†</sup>Factory wired Model AL-80B and AL-80BY

<sup>‡</sup>Factory wired Model AL-80BX

**DANGER:** *Never change jumpers with the power cord connected to an outlet.*



---

## Interconnections

---

1. Connect the exciter's RF output to the "RF IN" connector on the rear of the AL-80B with 50 ohm coax. Use any good quality 50 ohm cable long enough to connect the amplifier to the exciter. This amplifier connection uses a standard SO-239 female that mates with a PL-259 male connector on the cable.
2. Connect the existing station antenna system to the "RF OUT" connector on the rear of the AL-80B with RG-8 type coax. This amplifier connection uses a SO-239 female that mates with a PL-259 connector on the cable.
3. Shielded audio type cable with a standard male phono plug should be used to connect to the "RLY" jack on the AL-80B. This jack has positive 12 Vdc open circuit and supplies 100 mA of current when pulled to ground. The relay circuit has an internal back pulse canceling diode to protect sensitive exciter circuits from damage.
4. Connect a short, wide, smooth ground lead from a good earth and RF ground to the rear panel "GND" terminal. Avoid using braided conductors for ground leads.
5. The "12 V" connection on the rear panel provides 12 Vdc at 200 mA maximum to operate external dial lamps or accessories such as the ATR-15 Antenna Tuner.
6. Connect the "ALC" jack to the ALC input of the exciter with a shielded cable and a phono plug. The proper connection point on the exciter should be indicated in the exciter's manual. The AL-80B ALC will operate with any exciter that uses a negative-going ALC voltage of up to 10 volts.

**Note:** Transceiver ALC response times and ALC voltage requirements vary with different manufacturers.

---

## Operating Instructions And Guidelines

---

### Front Panel Controls

#### **"MULTIMETER" Switch**

This four position switch selects either the plate voltage (HV) of 0-3500 volts, the reflected peak envelope power (REF) of 0-500 watts, the ALC detector output voltage (ALC) of 0-35 volts, or the approximate ALC grid current threshold (ALC SET) of 0-350 mA. See the "Multimeter Functions" section on page 6 for more details.

#### **"OFF-ON" Switch**

This switch turns the main power off and on. When this switch is placed in the "ON" position, the fan should start, the meters should be illuminated, and high voltage should appear.

### **"STBY-OPR" Switch**

This switch disables the amplifier's internal antenna relay. In the "STBY" position the amplifier is bypassed without turning the tube's filaments or the power supply off.

This switch will also reset the grid protection circuit if an optional grid overload protection circuit is installed. The overload circuit will be reset whenever this switch is placed in the "STBY" position and returned to the "OPR" position.

### **"PLATE" Control**

The "PLATE" control adjusts the output tank circuit to resonance. This control should *always* be adjusted for maximum RF output power. Maximum RF output power normally occurs simultaneously with maximum grid current and very close to the plate current "dip."

### **"LOAD" Control**

This control adjusts the coupling of the amplifier to the antenna or load. This adjustment insures optimum coupling between the tube and the load as the SWR of the load, the operating frequency, or the power level is changed. Advancing the "LOAD" control clockwise increases the RF power output capability and the linearity of the amplifier. Advancing the "LOAD" control also *decreases* the grid current and *increases* the plate current for a given amount of drive.

The efficiency of the amplifier and the grid current decrease if the "LOAD" control is rotated beyond the point of maximum output. The linearity, however, will increase. The proper position for this control is *slightly* clockwise from the setting that produces maximum output with full drive power applied to the input. *Never use this control to adjust the output power.*

The "PLATE" control should always be checked after the "LOAD" control is adjusted by more than one number. This is especially important at the high end of the "LOAD" range on 20 meters and above. For example, if the "LOAD" is advanced from 7-1/2 to 8-3/4, the "PLATE" should be re-tuned. If the "LOAD" is touched up only a slight amount, the "PLATE" setting will not usually require re-adjustment.

## **ALC Metering, Controls, and Adjustments**

### **ALC Metering Functions**

The "MULTIMETER" switch in the AL-80B has two positions that indicate the functioning of the ALC circuit. These positions are as follows:

**ALC** In this position the multimeter measures the output voltage of the ALC detector. The full scale reading of the ALC detector is 35 volts. It is read directly from the ALC/ HV scale of the multimeter. The multimeter will indicate the maximum value of ALC voltage available from the internal ALC circuit. The meter should flick upwards occasionally during normal ALC action in this position.

---

## AL-80B Instruction Manual

**ALC SET** In this position the multimeter measures the *approximate* grid current that will produce ALC activity. One zero must be added to the reading on the ALC/ HV scale for this function.

For example: If the meter reads 15, add one zero (150). In this example ALC action will begin at *approximately* 150 mA of grid current.

### ALC Controls

The position of the "ALC SET" control determines the grid current value that will begin to produce ALC voltage. Rotating the "ALC SET" control counter-clockwise *reduces* the maximum grid current obtainable and the available RF power output. Rotating the "ALC SET" control clockwise *increases* the maximum grid current level.

The approximate grid current available before ALC action begins can be determined by placing the "MULTIMETER" switch in the "ALC SET" (far clockwise) position. The "ALC SET" control should normally be adjusted to produce a multimeter reading of 12 to 18 volts with the "MULTIMETER" switch in the "ALC SET" position. This will allow a maximum grid current of approximately 120 to 180 mA.

### ALC Adjustments

**During SSB operation**, two adjustments affect the ALC and the sound of the signal. One is the *exciter's* microphone gain (or RF output level) adjustment. It will control the "fullness" of the ALC and the average output power. It will have very little effect on the peak output power, however. The fullness of ALC action is indicated by the multimeter reading in the ALC position. More exciter audio gain or power output will drive the amplifier's ALC circuit harder, and produce a more constant meter reading. This produces RF compression that increases the "talk power" without increasing signal bandwidth or distortion.

**Note:** Audio background noise will increase while using heavy ALC levels on SSB. Objectionable background noise levels may occur while using heavy amounts of ALC, especially if the heavy ALC levels are used in conjunction with other speech processing. In these situations, operating in a quiet room and "close talking" the microphone will minimize objectionable background noise.

The amplifier's "ALC SET" control determines the *level* of grid current that produces ALC activity, the maximum power output level. This amplifier has the best linearity when the "ALC SET" control is adjusted to limit the peak grid current to 150 mA or lower. This adjustment must be made with a carrier or single tone signal. When the "ALC SET" control is properly adjusted, it will be impossible to exceed 150 mA of grid current with any tuning or drive adjustment.

**During CW operation**, the "ALC SET" control voltage should be adjusted just high enough (clockwise) to allow the desired output power to be reached. The "ALC SET" control should *never* be adjusted to the point where the grid current can exceed 200 mA under any tuning or drive adjustment condition. During proper CW ALC operation, the exciter drive level control should be adjusted until the ALC voltage meter slightly flickers (ALC position of the "MULTIMETER" switch) while operating with normal output power levels.

The ALC circuit will limit the amplifier's grid current to a safe value if anything accidentally changes in the station or the antenna. The CW keying waveform of the radio will remain unaltered when the ALC is adjusted in this manner.

**NOTE:** Caution should be exercised if the ALC SET is used to control the CW power output with the exciter power control set at maximum. Key clicks may be produced if the exciter has a poor ALC response time. Check for proper wave shape when using the ALC in the amplifier exclusively to control the RF output power.

### **Rear-panel "ALC LIMIT" control**

The "ALC Limit" control (rear panel) limits the maximum voltage available from the ALC circuit. This control is necessary only because the ALC response times and voltage requirements for exciters have never been standardized. The ALC voltage requirements may even vary between different models produced by the same manufacturer.

If the ALC response time of the exciter (transceiver) is faster than the rise time of the RF envelope, there will be no voltage compatibility problems. The ALC voltage from this amplifier will automatically self-adjust to the value required by the exciter.

If the ALC voltage requirements are low and/or if the ALC attack time is slow, the ALC may cause the output power to "pump" at a very slow rate. The undesired "pumping" can be corrected by reducing the amplifier's ALC output voltage with the "ALC Limit" control (R1).

A full counter-clockwise "ALC Limit" setting will produce approximately 10 volts of maximum negative ALC voltage. A full clockwise setting (viewed from amplifier rear) will produce no ALC voltage. Always start with this control fully counter-clockwise before slowly advancing this control clockwise. The "ALC Limit Adjustment" section that follows gives adjustment details.

An external 1,000 to 5,000 ohm potentiometer can be added from the ALC output line to ground if the particular amplifier you are using does not have a rear panel "ALC Limit" control. The chassis (shield) of the amplifier's ALC output jack must connect to the clockwise (shaft end view) terminal of the ALC exciter voltage control. The ALC jack center pin on the amplifier must connect to the counter-clockwise terminal (shaft end view) of the external control. The center of the control connects to the ALC input of the exciter.

### ALC Limit Adjustment (rear panel)

This adjustment procedure should be used if "pumping" occurs from excessive transceiver ALC sensitivity and/or slow transceiver ALC response time:

1. Load the amplifier for maximum output on any band (see tuning instructions later in this manual).
2. Adjust the "ALC SET" control on the front panel and the rear panel "ALC Limit" potentiometer to their full counter-clockwise positions.
3. Apply full exciter drive power, and adjust the rear panel "ALC Limit" potentiometer clockwise (rear view) until the amplifier's ALC output voltage meter (multimeter "ALC" position) indicates 6 to 10 volts. As an alternative, the potentiometer can be adjusted clockwise until the RF output power reaches 300-500 watts.
4. Adjust the front panel ALC SET control to the desired power level.

---

### Driving Power

---

This amplifier is designed to operate at full ratings when it is driven by an exciter that has approximately 70 watts of RF output. An exciter with a lower output power may be used with a resulting decrease in amplifier output. Both the driving power and the "LOAD" control must be carefully adjusted when using an exciter that delivers more than 70 watts. Proper control settings will help prevent excessive grid current and spurious signals, which create needless interference to other operators. A monitor scope is recommended for continuous output observation. An oscilloscope is the best way of determining if the amplifier is "flat-topping" and producing excessive distortion products.

A second method of determining linear operation is to monitor the peak RF output power carefully on the AL-80B's internal meter. Determine the maximum obtainable RF output power and reduce the exciter's power until there is a noticeable margin from the maximum output power. This will insure some reserve power is available for random voice peaks.

**NOTE:** Never increase the drive power beyond the point where the amplifier's output power stops increasing. This is also the point where the grid current will begin rising rapidly.

The amplifier is being over-driven for a given "LOAD" setting when the grid current increases rapidly while the plate current and output power increase slowly. The amplifier "LOAD" control needs to be *advanced* to a higher number if this condition occurs. Non-linear operation, splatter, and excessive grid current will occur if the "LOAD" setting is too low. Excessive plate current is the proper indicator that the drive power limit has been reached.

---

## Tube and Component Life

---

These guidelines will help prolong tube and component life, and minimize splatter.

1. On SSB or other linear modes, virtually *any* amount of power will cause splatter if the loading is too light ("LOAD" control too far counter-clockwise). Always tune for *maximum* output with *maximum* drive power. Reduce the *drive power* to reduce the output power on SSB, not the loading control.
2. Lightly loading an amplifier will also result in large voltages building up in the tank circuit. Under-loading an amplifier is much harder on the tubes and other components than operating a properly loaded amplifier into a high SWR or with excessive drive power.
3. Never depend on *average* reading power or current meters to indicate proper operation on SSB or other linear modes. The best indicator of linearity is either an oscilloscope or the internal PEP RF output meter. Maximum linearity can be determined by finding the maximum output power possible and then reducing the *exciter power* for a slight reduction in output power.
4. Never *exceed* 170 mA of grid current on CW carrier during actual operation. The proper grid current for SSB will range from 0 to 75 mA. The SSB grid current will vary with the operator's voice, the amount of signal compression or processing, and the tube characteristics.

---

## Tuning

---

Follow the instructions below in numerical order. Proper tuning will produce excellent output power, a clean signal, and good tube life. If the various meter readings are different than indicated in the text, check the external amplifier connections. Consult the manual for the exciter if necessary.

**WARNING:** The transformer must be wired correctly for your line voltage. This amplifier is normally shipped wired for standard 120Vac operation. Refer to the "Transformer Connection" section on page 12 for details.

### Tuning Procedure

**Important Note:** If you have installed the optional electronic grid protection circuit to prevent control-grid damage, this amplifier will quit operating if the grid dissipation exceeds a safe pre-set limit. *The overload circuit responds much faster than the grid current meter.* The overload circuit can respond to excessive grid current before the operator is able to observe excessive current on the grid meter.

Some exciters generate brief high-level RF pulses when first keyed. These short duration pulses may greatly exceed the exciter's operating output power setting but may not be indicated on meters. Unexplained activation of the grid overload circuit may indicate the existence of this exciter problem. The grid overload circuit can be reset by momentarily placing the "STBY-OPR" switch in the "STBY" position.

---

## AL-80B Instruction Manual

Never under-load the amplifier to reduce the output power. The amplifier "LOAD" control must be set to a high enough position (clockwise) to prevent excessive voltage and arcing in the tank circuit or excessive grid current. Repeated tripping of the grid overload circuit or intermittent arcing probably indicates the "LOAD" control is adjusted too low.

1. Set the AL-80B front panel switches as follows:

**POWER**           to   **OFF**  
**OPR-STBY**       to   **STBY**  
**MULTIMETER**   to   **HV**

2. Plug the ac line cord into the proper voltage outlet.
3. Place the main power switch in the "ON" position. The meter lamps should light and the blower should start. Read the 3500 volt scale on the multimeter. It should indicate 3100 volts nominal and no more than 3200 volts.
4. With the amplifier still on "STBY", tune the exciter into a normal 50 ohm load according to the manufacturer's instructions (solid state radios do not normally require this adjustment). Turn the exciter drive down after tuning.
5. Place the amplifier's "BAND" switch on the same band as the exciter. Set the "PLATE" control and the "LOAD" control as indicated below:

### CW

| Frequency | PLATE | LOAD  |
|-----------|-------|-------|
| 1.810     | 3-1/4 | 2-1/2 |
| 3.600     | 2-3/4 | 1-1/2 |
| 7.050     | 7-1/4 | 4-1/2 |
| 10.125    | 6     | 0     |
| 14.050    | 8-1/2 | 5-1/4 |
| 18.125    | 8-1/4 | 4-1/2 |
| 21.050    | 9     | 7     |
| 24.900    | 8-3/4 | 6-1/4 |
| 28.050    | 8-1/4 | 7-3/4 |

### PHONE (SSB)

| Frequency | PLATE | LOAD  |
|-----------|-------|-------|
| 1.850     | 4     | 3     |
| 3.900     | 3-1/2 | 3-3/4 |
| 7.200     | 7-1/2 | 4-1/2 |
| 14.250    | 8-1/2 | 5-1/2 |
| 21.350    | 9     | 7     |
| 28.500    | 9-1/4 | 8     |

6. With the exciter's drive level still on zero, observe the 750 mA  $I_p$  scale on the left hand meter. It should indicate zero (0) amperes.
7. Place the "STBY-OPR" switch in the "OPR" position. Place the exciter in the transmit mode with no RF output. The red "XMT" LED should light and the plate current ( $I_p$  on the left meter) should be close to zero (0).
8. With the exciter in the transmit mode, apply a very low amount of RF drive power (about 100 mW). The plate current ( $I_p$ ) should suddenly increase to nearly 100 mA.

**Note: Currents may vary up to 25% due to component and line voltage tolerances. If the current in this step is higher than expected, the RF level from the exciter may be too high.**

If the exciter does not allow adjustment to very low CW power levels, the exciter can be placed in the SSB mode and the audio (microphone) gain control advanced from minimum while speaking until the plate current ( $I_p$ ) just flickers upwards. The plate current ( $I_p$ ) should be around 100 mA on these flickers.

9. Place the "MULTIMETER" switch in the "ALC SET" position. Adjust the front panel "ALC SET" control until the multimeter indicates 10 volts. This adjustment will limit the amplifier's grid current to approximately 100 mA.

STEPS 10a and 11a REQUIRE A CONNECTION FROM THE AMPLIFIER'S ALC OUTPUT TO THE EXCITER'S ALC INPUT.

STEPS 10b and 11b SHOULD BE USED IF THE EXCITER AND AMPLIFIER ALC LINES ARE NOT CONNECTED.

**Note: Step 10 requires the simultaneous observation of the plate current ( $I_p$ ) and the grid current ( $I_g$ ).**

- 10a. If the ALC line is connected, adjust the exciter's drive or power output control to maximum. NEVER ALLOW THE GRID CURRENT ( $I_g$ ) TO EXCEED 120 mA OR THE PLATE CURRENT ( $I_p$ ) TO EXCEED 400 MILLIAMPERES AT THIS STAGE OF TUNING. If either current exceeds these limits, reduce the 'ALC SET' control. Adjust the 'PLATE' control for maximum output power. The plate current ( $I_p$ ) of the amplifier and the output power of the exciter should dip (decrease) when this adjustment is made.
- 10b. If the ALC is not connected, place the exciter in the transmit mode and gradually increase the drive until a grid current of 100 mA **or** a plate current of 400 milliamperes (whichever is higher) appears. The "PLATE" control should be adjusted until maximum grid current and maximum RF output power appear. The plate current ( $I_p$ ) should now dip slightly. The drive power should be removed.



---

## AL-80B Instruction Manual

- 11a. Increase the "ALC SET" voltage (if the ALC is connected) until 180 mA (18 volts) is indicated. Apply full drive (not to exceed 100 watts) and adjust the "LOAD" and "PLATE" controls for maximum RF output power. The grid current should not be allowed to go above 200 mA at this stage. The plate current should not be allowed to exceed 600 mA during brief periods of tuning (15 seconds).
- 11b. Increase the exciter drive power (if the ALC is not connected) until 180 mA of grid current is indicated. Adjust the "LOAD" and "PLATE" controls for maximum RF output power. The grid current should not be allowed to go above 200 mA at this stage. The plate current should not be allowed to exceed 600 milliamperes during brief periods of tuning (15 seconds).
- 12a. For CW operation, the output power should be reduced with the "ALC SET" control until the rated output power of 800 watts is obtained. The "LOAD" control should be adjusted until minimum plate current is obtained without dropping below 800 watts. The exciter's power can be reduced until the multimeter shows a slight upward flicker with the "MULTIMETER" switch in the ALC position if the ALC is used.
- 12b. For SSB operation, the "ALC SET" should be adjusted to allow 200 mA of grid current (near the 20 volt marking). The exciter should be set to produce maximum output power (not to exceed 100 watts of peak power). Next the amplifier's "LOAD" and "PLATE" controls are adjusted for maximum power output on the internal peak reading RF wattmeter with either a two-tone generator or sustained "HEL-L-L-L-L-O" driving the exciter. The "ALC SET" control should then be reduced until the peak power output is slightly lowered. Finally the exciter's audio gain or output power is adjusted until the multimeter "ALC" position indicates the desired ALC level. This setting should normally allow around 150 mA grid current on a steady carrier or "whistle".

**Note: If the ALC is not connected, the amplifier must be fully loaded for maximum output with maximum drive (not to exceed 100 watts). The exciter's output should then be reduced until 1000 watts PEP is obtained.**

### "ALC SET" control

Proper adjustment of the front panel "ALC SET" control accomplishes the following:

1. Exciter's power is limited to a value that produces a predetermined maximum grid current in the amplifier. The front panel "ALC SET" control determines the maximum grid current obtained.
2. The "LOAD" control setting determines the maximum plate current and output power for a given grid current. Never exceed 600 mA of short duty cycle (or 400 mA of long duty cycle) plate current. Never exceed 200 mA of operating grid current.
3. For normal SSB operation, the exciter power should be reduced until the ALC voltage (measured in the ALC multimeter position) flicks upwards on occasional voice peaks. This will produce the best audio quality. The drive can be increased for DX or weak signal SSB operation until the ALC steadily registers voltage.

*Also see the "ALC Adjustment" section on page 15, and the "Multimeter" section on page 6.*

---

## Additional SSB Notes

---

The peak power output developed on SSB is limited by the amplifier loading, RF drive, and peak-to-average power of the RF waveform. Proper loading of this amplifier will produce excellent linearity and a clean signal even if the output power level exceeds one kilowatt PEP. An improperly adjusted (too far counter-clockwise) "LOAD" adjustment can produce flat-topping and splatter with only a few hundred watts of RF output. The "LOAD" setting is the single most important adjustment for proper SSB operation.

**Note: The "LOAD" control setting is the most important adjustment for good linearity!**

To maintain linearity, *always* be sure that the "LOAD" control is adjusted far enough *clockwise* for the *peak* drive that will be applied.

Be considerate of others, NEVER "push" this amplifier into envelope clipping or to the point where the grid current approaches 75 mA on voice peaks. Envelope clipping can also be avoided by adjusting the amplifier's "ALC SET" control until the peak output power drops slightly from the power obtained with full microphone gain and a fully clockwise "ALC SET" adjustment. For the cleanest audio, the microphone gain can be reduced until the ALC meter just flickers.

---

## AM (Amplitude Modulation) Operation

---

The efficiency of *any* conventional linear amplifier must remain below half the peak efficiency under maximum signal conditions (less a safety factor) in AM operation. Since this linear amplifier has a peak plate efficiency of nearly 65%, the carrier efficiency must be kept below 30% to maintain linearity. The power dissipated in the tube anodes will be more than twice the carrier output power.

The carrier power must be kept below 200 watts for clean and safe AM operation. With 200 watts of carrier, the peak envelope power will reach 800 watts with 100% symmetrical modulation. The modulated AM power output should be limited to 1000 watts peak with non-symmetrical modulation that enhances the positive peaks.

---

## FM (Frequency Modulation), RTTY, and Digital Operation

---

The efficiency of this amplifier will approach 65% in the FM, RTTY and Digital Operation modes. Since these modes do not require linear amplification of complex waveforms, the tuning can be re-adjusted for maximum power at the desired output power level. This will keep the efficiency as high as possible.

---

## Audio Distortion

---

One problem that often occurs when using a linear power amplifier is SSB audio distortion on one or more bands. This distortion is usually caused by RF feedback from either a poorly designed antenna or poor RF grounding. *REMEMBER THAT A GOOD GROUND FOR DC IS NOT NECESSARILY GOOD FOR RF.* RF circuits require short connections with smooth, wide conductors. Braiding or woven wire has a very high RF resistance and should be avoided. See the "Grounding" section on page 11 of this manual. More detailed suggestions on grounding are available by requesting Ameritron's Tech Bulletin on RF Feedback.

---

**QSK Operation**

---

The antenna transfer relay in the AL-80B takes approximately 15 milliseconds to change states. This precludes using the standard internal relay for QSK CW operation. Commonly available vacuum relays are specified at 5 to 7 milliseconds of switching time. Even expensive vacuum relays are less than ideal for high speed QSK operation. At 60 WPM, less than 50% of the receive-time is available with vacuum relays.

On PACKET, AMTOR, and other modes, delay can be added to the transmit and receive changeover to use either vacuum or our standard relay effectively. Ameritron offers two high-speed PIN diode options that permit operation on modes requiring high speed receive-transmit switching. Both systems offer noiseless switching times of under one millisecond. Since PIN diode systems are several times faster than vacuum relay systems, they allow over 90% of the available receive time to be used at 60 WPM.

Ameritron highly recommends using the external QSK-5 switch. This stand alone PIN diode switch can be used with almost all types of amplifiers and transmitters. Modifications are not required in amplifiers used with the QSK-5 unit. The QSK-5 operates directly from 120 Vac power lines.

Ameritron also offers an internal QSK board as a space-saver for the AL-80B. This internal board is slightly less expensive. However, it provides less flexibility and serviceability than the external QSK-5 unit. Factory installation of the QSK-5PC is highly recommended. Contact Ameritron for details on the QSK-5 and the QSK-5PC.

---

**Periodic Maintenance**

---

The high voltage present on various parts of the amplifier will attract dust and dirt. The high voltage areas at the bottom of the plate choke and the plates and insulators of the air variable capacitors should be kept dust free. These areas should be inspected periodically, especially if the amplifier is operated in a dusty environment. These areas may be inspected by unplugging the line cord and waiting a few minutes for the power supply capacitors to discharge. The high voltage should then be checked with the internal multimeter by placing the meter switch in the HV position.

|  |
|--|
| <b>WARNING</b> High voltages can kill!!! Accidental contact with the voltages in this amplifier can be lethal! |
|--|

For your personal safety, please observe the following precautions:

1. **NEVER** defeat the interlock.
2. **NEVER** remove the cover with the amplifier connected to the power line.
3. **ALWAYS** allow several minutes for the capacitors to discharge *after* unplugging the amplifier and *before* removing the cover.
4. **ALWAYS** select the high-voltage (HV) function of the Multimeter to check the high voltage potential. Do **not** remove the cover if voltage is indicated.
5. **ALWAYS** ground the tube anode (top metal conductor) to the chassis before touching anything inside the amplifier.
6. **ALWAYS** be cautious of heat. Many components inside the amplifier operate at high temperatures.
7. **NEVER** make any unauthorized component or circuit modifications to this product. The *only* acceptable source for modifications is Ameritron or a source approved by Ameritron. Unauthorized modifications almost certainly will **increase** the risk of equipment failure or personal injury.

The cover should be removed and a low value (40 to 500 ohm) two-watt or larger resistor should be secured to the chassis. The other end of this resistor should be connected to the tube anode with an insulated clip lead.

**CAUTION: NEVER ground the anode directly to the chassis without a series resistor. Component damage may occur from the current surge.**

**Note: This resistor is a safety device that must be installed when beginning service work and removed when the work is finished.**

Dust and dirt can be blown out of the amplifier with a shop vacuum or a high pressure air hose. A soft bristle brush dipped in alcohol can be used to clean particularly dirty areas. If the amplifier is operated in a dusty environment, a non-conductive low-restriction foam air filter can be placed over the ventilation holes on the left side of the cabinet near the filter capacitors. Placing an air filter over these air inlet holes will substantially reduce the amount of dust entering the cabinet. Most hardware stores stock suitable air filter material that are used as replacement filters for window air conditioners.

## Parts List

## Power Supply / SWR Board (50-0080-1)

| Designator               | Description                         | Ameritron PN |
|--------------------------|-------------------------------------|--------------|
| D101,102,114,115         | 1N34A                               | 300-0346     |
| D103                     | 1N757A Zener 9.1V                   | 305-0757     |
| D116-120                 | 1N4001                              | 300-0266     |
| D104-113                 | 1N5408                              | 300-0145     |
| C101                     | 27 pF 500 V                         | 208-5404     |
| C102,105                 | .001 uF 1 kV                        | 200-2120     |
| C103                     | 10 pF 1 kV                          | 200-3531     |
| C104                     | 3-12 pF 500 V Trim                  | 204-0150     |
| C106,125,126,129,135-137 | .01uF 50 V Disc                     | 200-0416     |
| C140                     | .47 uF                              | 203-0530     |
| C107-116                 | .01 uF 1 kV                         | 200-2121     |
| C117-124                 | 210 uF 450 V Elect.                 | 203-0578     |
| C127                     | 270 pF 500 V                        | 208-5775     |
| C128,138,132,139         | .1 uF 50 V                          | 200-0754     |
| C130,131                 | .01 uF 250 Vac                      | 200-2122     |
| C133                     | 2200 uF 25 V                        | 203-0207     |
| C134                     | 220 uF 25 V                         | 203-0565     |
| R101                     | 4.7k mox 1 W                        | 103-1747     |
| R102                     | 470k 1/4 W                          | 100-0188     |
| R103,104,121             | 10k 1/4 W                           | 100-4100     |
| R105                     | 10 ohm 1/2 W                        | 100-0727     |
| R106                     | 1.5 ohm 2 W 1%                      | 103-3400     |
| R107                     | 0.6 ohm 3 W 1%                      | 103-3399     |
| R108,109                 | 1M 3 W 1% special high voltage type | 103-2223     |
| R110,111                 | 750k 2 W mox 2%                     | 103-1743     |
| R112-119                 | 50k 7 W 5%                          | 103-7580     |
| R120                     | 51ohm 2 W mox 5%                    | 103-2151     |
| R122                     | 6.8k 1/4 W                          | 103-1747     |
| R123                     | 1.8k 1/4 W                          | 100-0728     |
| R124,125                 | 50k trim pot                        | 104-0400     |
| R126,128,128             | 47k 1/2 W                           | 101-0402     |
| R127                     | 10 ohm 10 W                         | 103-9702     |
| R130                     | 47 ohm 1/2 watt                     | 101-1470     |
| RLY101                   | 3PDT 12 Vdc                         | 408-6140     |
| RLY102                   | SPST 12 Vdc                         | 408-6148     |
| RFC101                   | Choke 3 turns FB-73                 | 10-15168     |
| T101                     | Toroid                              | 10-14134     |
| Q101                     | 2N3904                              | 305-0645     |
| Q102                     | 2N3906                              | 305-0722     |
| Q3 (see main chassis)    | MJF3055 transistor, NPN             | 305-3055     |
| F101                     | 2 A                                 | 755-1102     |

**Tuned Input Board (50-0080-2)**

| Designator              | Description     | Ameritron PN |
|-------------------------|-----------------|--------------|
| C201 (tube side)        | See input chart |              |
| C202 (transmitter side) | See input chart |              |
| L201                    | See input chart |              |
| S201                    | Input switch    |              |

**AL-80B Tuned Input Chart**

| BAND  | C201 (pF) tube |            | L201   |            | C 201 (pF) transmitter side |            |
|-------|----------------|------------|--------|------------|-----------------------------|------------|
| 160   | 2700           | (208-5689) | 28.75T | (405-1287) | 2000                        | (208-5608) |
| 80    | 1300           | (208-5177) | 23.75T | (405-1237) | 1000                        | (208-5176) |
| 40    | 820            | (208-5381) | 13.75T | (405-1137) | 500                         | (208-5691) |
| 20/30 | 470            | (208-5440) | 9.75T  | (405-1097) | 270                         | (208-5775) |
| 15/17 | 360            | (208-5688) | 6.75T  | (405-1067) | 220                         | (208-5175) |
| 10/12 | 220            | (208-5175) | 4.75T  | (405-1047) | 180                         | (208-5396) |

**Meter Board (50-0080-3)**

| Designator                   | Description          | Ameritron PN |
|------------------------------|----------------------|--------------|
| D301                         | 1N34A                | 300-0346     |
| C301, 302                    | .47 uF 50 V tantalum | 203-0530     |
| C303, 304, 307-311, 314, 315 | .1 uF 50 V           | 200-0754     |
| C305, 306                    | .001 uF 1 kV         | 200-2120     |
| R301, 302                    | 2.2M 1/4 W           | 100-6220     |
| R303                         | 390 ohm 1/4 W        | 100-0390     |
| R304                         | 2.2k 1/4 W           | 100-1500     |
| R305                         | 470k 1/4 W           | 100-0188     |
| R306, 310                    | 10k 1/4 W            | 100-4100     |
| R307                         | 100 ohm 1/4 W        | 100-2100     |
| R308, 311                    | 33k 1/4 W            | 100-3330     |
| R309                         | 4.7k 1/4 W           | 100-1470     |
| R312                         | 330 ohm 1/4 W        | 100-0330     |
| R313                         | 270 ohm 1/4 W        | 100-0600     |
| IC301                        | LM324                | 311-0324     |
| Q301, 302                    | 2N3904               | 305-0645     |
| Q303                         | 2N3906               | 305-0722     |
| S301                         | Rotary 2P6T          | 500-0563     |

**Timer / Overload Board (50-0080-5)**

| <b>Designator</b> | <b>Description</b>     | <b>Ameritron PN</b> |
|-------------------|------------------------|---------------------|
| C501-506          | .01 uF 50 V disc       | 200-0416            |
| C507,508          | .47 uF tantalum        | 203-0530            |
| C509              | 100 uF 25 V            | 203-0564            |
| D501, 502         | 1N4001                 | 300-0266            |
| D503              | 5.6 V zener            | 301-710             |
| IC501             | LM 358 dual op-amp     | 311-0724            |
| Q501              | NPN transistor MJF3055 | 305-3055            |
| Q502              | PNP transistor 2N3906  | 307-0722            |
| Q503, 504         | NPN transistor 2N3904  | 305-0645            |
| R501-503          | 10k 1/2 W              | 101-0643            |
| R504, 505         | 3.3k 1/4 W             | 100-0729            |
| R506, 508         | 680 ohm 1/4 W          | 100-0532            |
| R507              | 1.8k 1/4 W             | 100-0728            |
| R509              | 1 meg 1/4 W            | 100-0730            |
| R510              | 1k 1/4 W               | 100-0727            |
| R511              | 180 ohm 1/2 W          | 101-0384            |
| RLY501            | DPDT 12 V dip relay    | 408-2135            |
| FB                | FB 73-801 Ferrite Bead | 10-15168            |

## AI-80B Main Chassis Parts List

| Designation | Description   | Ameritron PN |
|-------------|---|--------------|
| B1          | Blower  | 410-3138     |
| C1-3        | .001 uF 7.5 kV  | 200-7224     |
| C4          | 500 pF Doorknob 7.5 kV  | 210-0470     |
| C5, 6       | 170 pF Doorknob 7.5 kV  | 209-0559     |
| C7          | Air Variable Plate  | 204-2112     |
| C8          | Air Variable Load   | 204-2573-1   |
| D1          | LED, Red  | 320-0522-1   |
| F1, 2       | See Jumper Connections Chart, (page <b>Error! Bookmark not defined.</b> ) | -----        |
| 50-0080-1   | Power Supply / SWR Board Assembly   | 50-0080-1    |
| 50-0080-2   | Input Circuit Board Assembly  | 50-0080-2    |
| 50-0080-3   | Metering Board Assembly   | 50-0080-3    |
| 50-0080-4   | RF Tank Board Assembly (only parts L1-L2)                                 | 50-0080-4    |
| 50-0080-5   | Timer-Overload Board Assembly (optional.-See page 27)                     | 50-0080-5    |
| L1          | "L " Coil   | 10-13165     |
| L2          | LF Coil (mounted on 50-0080-4)  | 10-13240     |
| L3          | HF Coil (mounted on 50-0080-4)  | 10-13108     |
| M1          | Meter (Forward and Reflected)   | 400-3581     |
| M2          | Meter (grid and plate)  | 400-3580     |
| R1          | 1 k pot (ALC limit)   | 105-1301     |
| R2          | 100 k pot (ALC SET)   | 105-1341     |
| RFC1        | Parasitic choke   | 10-15105     |
| RFC2        | Plate Choke   | 10-15197     |
| RFC3        | 2.5 mH Choke  | 402-1162     |
| S1          | Band Switch   | 500-2135     |
| S2          | Lighted Switch  | 507-1157     |
| S3          | Rocker Switch   | 507-1150     |
| S4          | Interlock Switch  | 504-3247     |
| R3          | 33 ohm 1/4 watt   | 100-1330     |
| Q3          | Transistor MJF-3055   | 305-3055     |
| T1          | Transformer   | 406-1109-2C  |
| V1          | 3-500Z Tube   | 350-0167     |



**Frequency Coverage**

| AL-80B     |                | AL-80BX    |                |
|------------|----------------|------------|----------------|
| 160 meters | 1.8-2.0 MHz    | 160 meters | 1.8-2.0 MHz    |
| 80 meters  | 3.3-4.4 MHz    | 80 meters  | 3.3-4.4 MHz    |
| 40 meters  | 6.3-8.3 MHz    | 40 meters  | 6.3-8.3 MHz    |
| 20 meters  | 10.1-15.5 MHz  | 20 meters  | 10.1-15.5 MHz  |
| 15 meters  | 16.5-21.5 MHz* | 15 meters  | 16.5-21.5 MHz* |
|            |                | 10 meters  | 24-29 MHz*     |

\* Operation on 11-13 MHz, 15.5-16.5 MHz, and 25-27.9 MHz will damage components.

**Amplifier Tuning Log**

| <b>Band</b> | <b>"LOAD"</b> | <b>"PLATE"</b> |
|-------------|---------------|----------------|
| 160 CW      |               |                |
| 160 SSB     |               |                |
| 80 CW       |               |                |
| 75 SSB      |               |                |
| 40 CW       |               |                |
| 40 SSB      |               |                |
| 30 CW       |               |                |
| 20 CW       |               |                |
| 20 SSB      |               |                |
| 17 CW       |               |                |
| 17 SSB      |               |                |
| 15 CW       |               |                |
| 15 SSB      |               |                |

Fill in this log with the amplifier settings to quickly change bands. Use a pencil as settings may change with different antennas.

**Notes:**

# AL-80B WIRING DIAGRAM

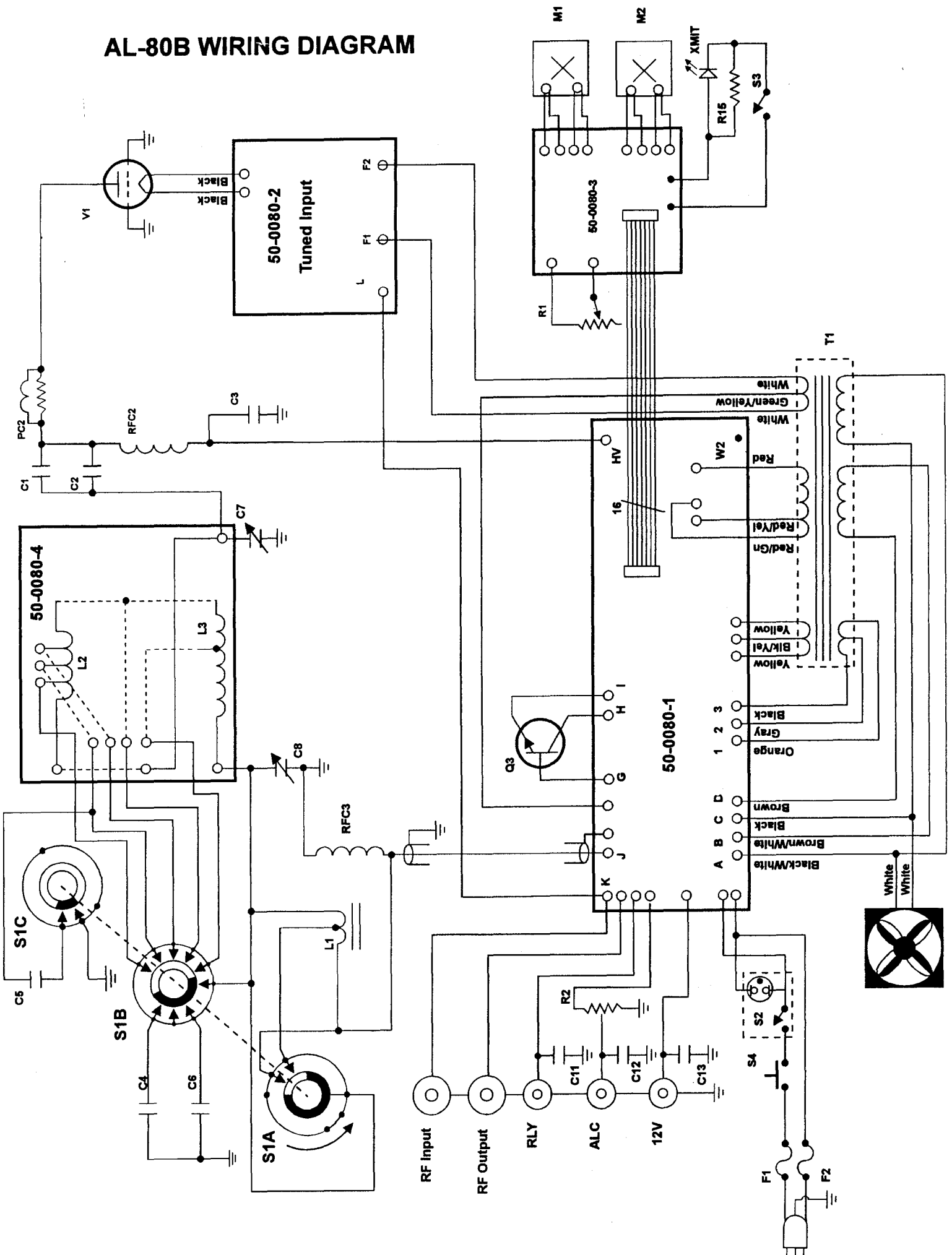

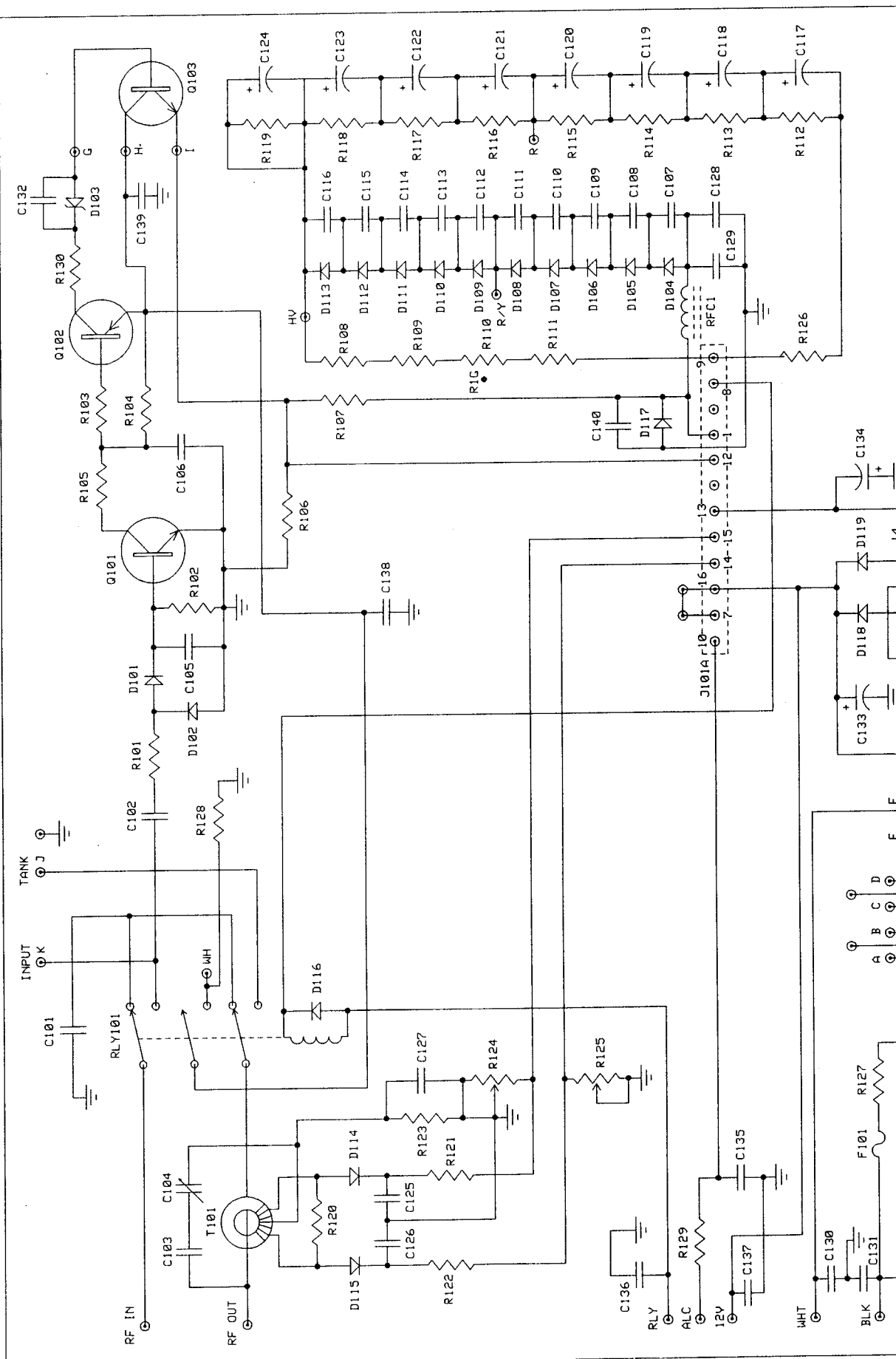

|                             |          |                               |           |              |
|-----------------------------|----------|-------------------------------|-----------|--------------|
| MODEL NO.                   | REVISED  | PCB P/W                       | 50-0080-1 | SHEET 1 OF 3 |
| AL-80B                      |          | DESCRIPTION                   |           |              |
| <b>PWR SUPPLY/SWR BOARD</b> |          |                               |           |              |
| DATE                        | PC BOARD | AMERITRON                     |           |              |
| 08/14/95                    | A80BPM   | 116 WILLOW ROAD               |           |              |
| REVISED                     | DRAWN BY | C. PERRY STARKVILLE, MS 39759 |           |              |

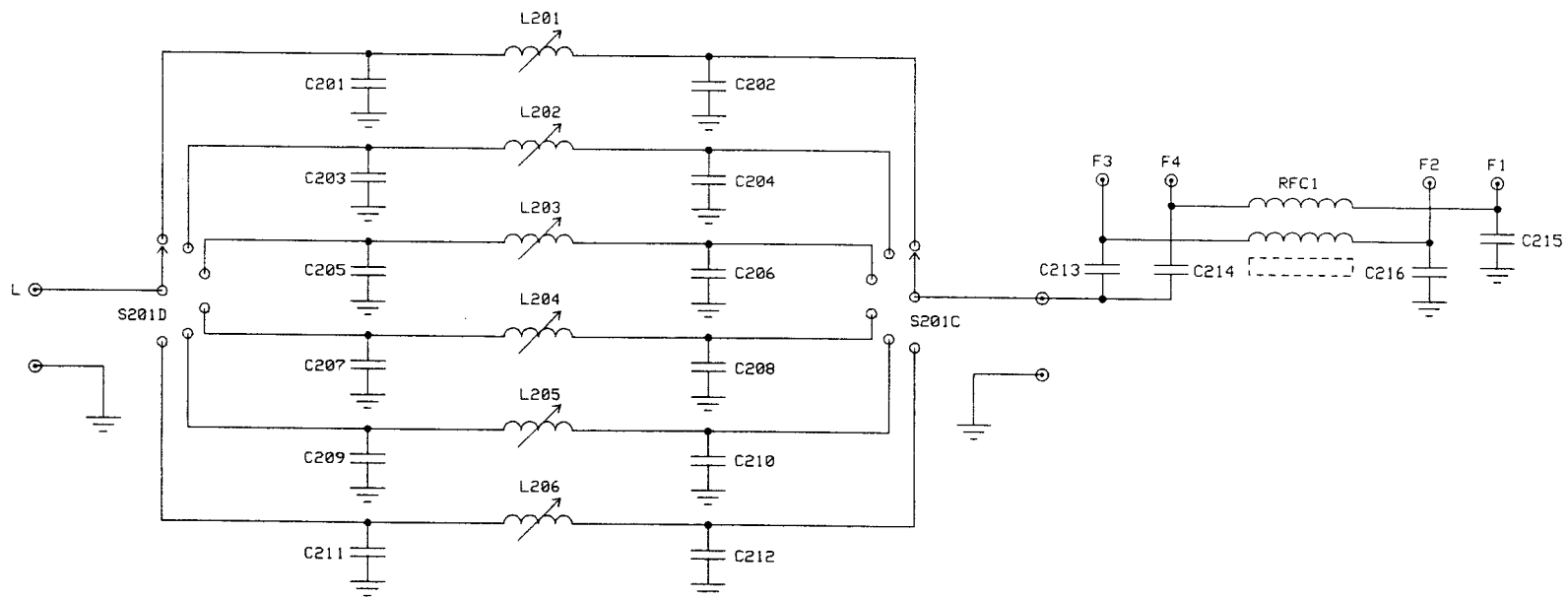

|             |          |                      |              |
|-------------|----------|----------------------|--------------|
| MODEL NO.   | REVISION | PCB P/N              | SHEET 2 OF 3 |
| AL-80B      |          | 50-0080-2            |              |
| DESCRIPTION |          |                      |              |
| INPUT BOARD |          |                      |              |
| DATE        | PC BOARD | AMERITRON            |              |
| 08/14/95    |          | 116 WILLOW ROAD      |              |
| REVISED     | DRAWN BY | STARKVILLE, MS 39759 |              |
|             | C. PERRY |                      |              |

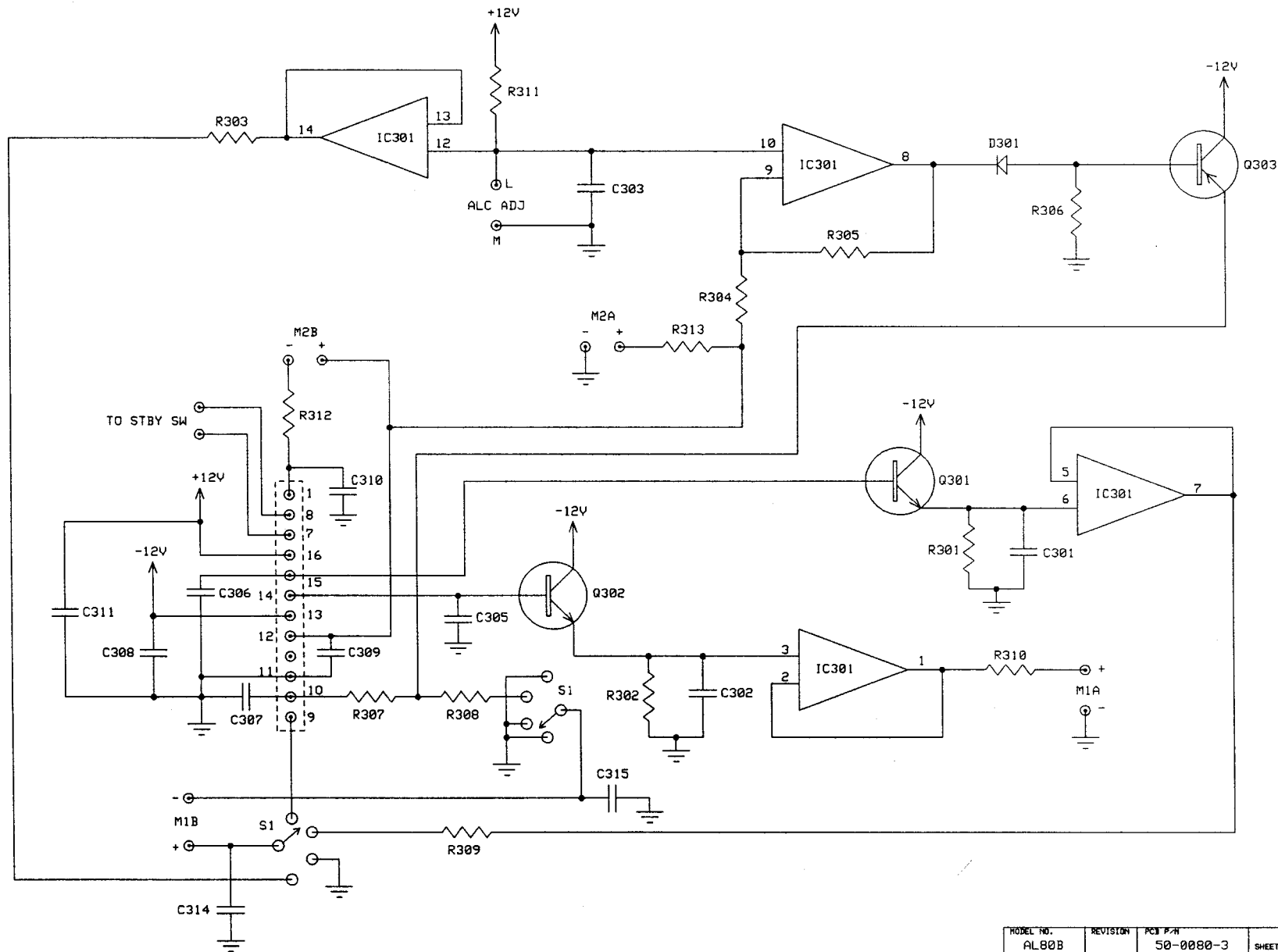

|             |          |                      |              |
|-------------|----------|----------------------|--------------|
| MODEL NO.   | REVISION | PCB P/N              | SHEET 3 OF 3 |
| AL80B       |          | 50-0000-3            |              |
| DESCRIPTION |          |                      |              |
| METER BOARD |          |                      |              |
| DATE        | PC BOARD | AMERITRON            |              |
| 08/14/95    |          | 116 WILLOW ROAD      |              |
| REVISED     | DRAWN BY | STARKVILLE, MS 39759 |              |
|             | C. PERRY |                      |              |